

PROFESSIONAL MANUFACTURER OF

FILLING MACHINE

灌装机专业制造商

温州大格机械科技有限公司

WENZHOU GRAND MACHINERY TECHNOLOGY CO. LTD

地址：浙江省温州市平阳县万全镇兴隆路116号

温州大格机械科技有限公司

Add:Wenzhou Grand Machinery Technology Co.,Ltd.No.116,Xinglong Road,
Wanquan Town, Pingyang County, Wenzhou City, Zhejiang Province, China.

TEL: (86 577) 65565188/65565288

FAX: (86 577) 65565288



温州大格机械科技有限公司

GENERAL MANAGER SPEECH

总经理致辞

一站式服务

创业至今已有十余载了，可谓经营十余载、风雨十余载、收获十余载。从单机设备立业到生产线全套设备，以标准机型到非标准化定制设备，凝聚了大格员工血汗和智慧铺就的奋斗之路，我们感谢社会各界对大格的大力支持和无私厚爱，感谢辛勤工作在各个岗位上战战业业的同仁们！

君子务本，本立而道生；敬事而信，直道而事人，每一个人在生活和工作中闪耀着务实求精和诚以待人的光辉，使我们的合作者和我们一样倍加信心百倍地迎接朝阳，以诚相待、以信为本、以优取胜、是大格的经营理念，是携刻于每个大格员工内心的座右铭，也是我们为客户提供优质设备的动力和信念。

德不孤，必有邻；忠恕之道，仁者爱人。优秀的思想源于优秀的文化，内修其身、外行其道，以人为本是大格企业文化的精髓。求真务实、待人宽诚、追求博大精深、发展永无止境。我们将继往开来，孜孜追求卓越品质和服务，营造真诚协作、开拓进取的共赢格局。

以良好的品行来推动企业的发展，渴望与各界朋友继续同心携手。

感恩！感谢您们对大格的信任，支持和帮助！



董事长签字：符木江

It has been more than ten years since I started my business which can be described as more than ten years of operation more than ten years of wind and rain, and more than ten years of harvest. From the establishment of single machine equipment to the complete set of production line equipment, from standard models to non standardized customized equipment it embodies the hard work and wisdom of Dage employees on the road of struggle. We thank all sectors of society for their strong support and selfless love to Dage and thank our colleagues who have worked hard in various positions to fight for their careers! A gentleman's duty is fundamental, and the Tao is born from the foundation. Respectful and trustworthy, straightforward and honest, everyone shines with the brilliance of pragmatism, excellence and sincerity in their life and work, making our partners as confident as us to welcome the sunrise. Honesty, trustworthiness, and excellence are the business philosophy of Dage, engraved in the hearts of every Dage employee, and also the driving force and belief for us to provide customers with high-quality equipment.

Virtue is not alone, there must be neighbors; The way of loyalty and forgiveness is for the benevolent to love others. Excellent ideas stem from excellent culture, cultivating oneself internally and learning externally. Putting people first is the essence of the corporate culture of Dage. Seeking truth and pragmatism, treating people with kindness and sincerity, pursuing profoundness and profundity, and developing endlessly. We will carry forward the past and open up the future, diligently pursue excellent quality and stock affairs, and create a win-win pattern of sincere cooperation and pioneering progress. To promote the development of the enterprise with good conduct, and eager to continue working together with friends from all walks of life. Thank you! Thank you for your trust, support, and assistance towards Dage!

COMPANY PROFILE

企业简介

一站式服务

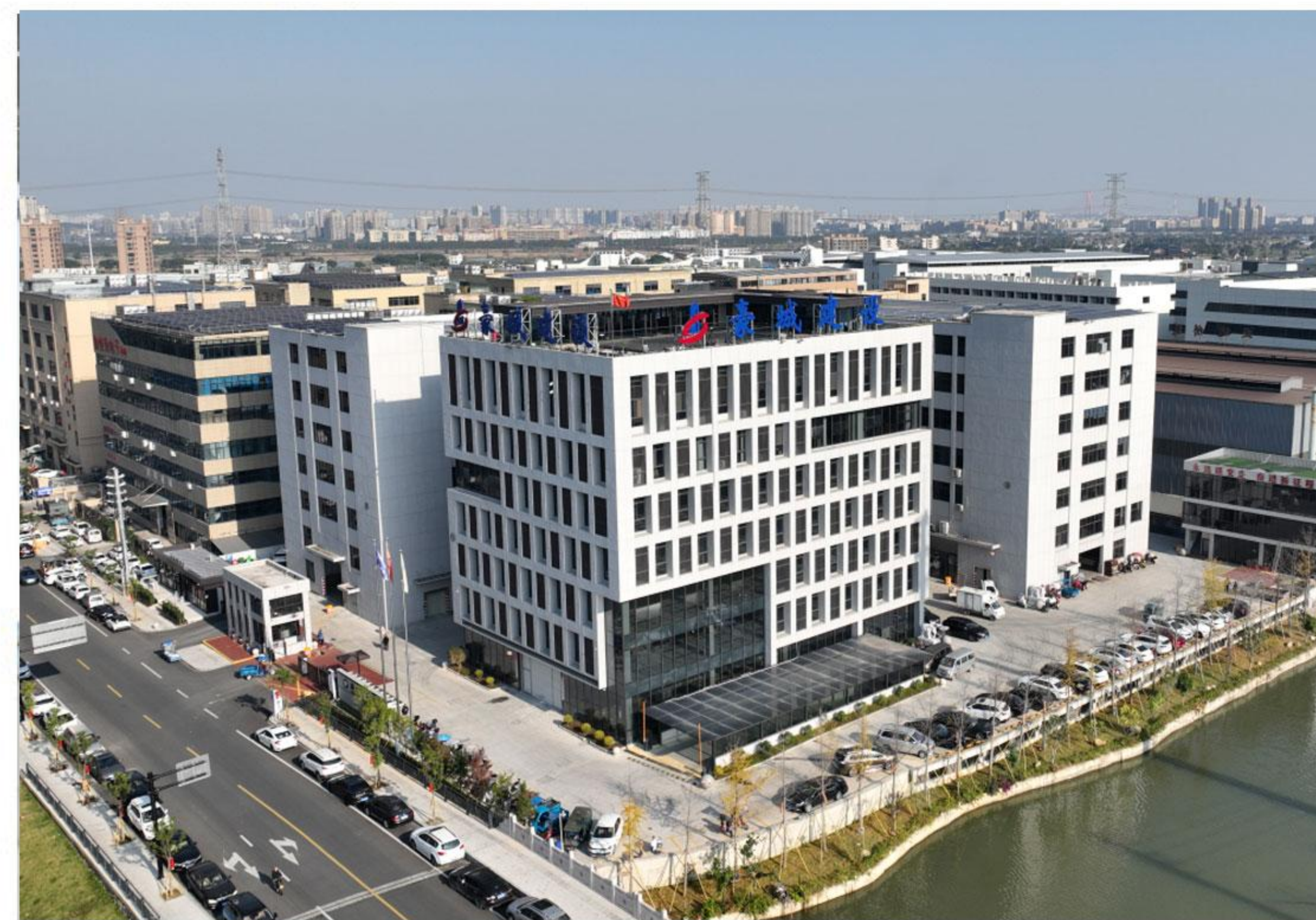

Wenzhou Dage Machinery Technology Co., Ltd. is located in the industrial city of Wenzhou]China, rooted in the fertile soil of mechanical manufacturing. The company focuses on the fields of pharmaceuticals and packaging machinery, and has gone through 23 years of development, Striving for excellence has become a leader in the industry. Dage Machinery is like a giant ship in the machinery industry, with a wide range of products under its umbrella, Covering liquid filling and sealing machines, blister packaging machines, capsule filling machines, boxing machines, grinding machines, granulators, dryers Mixing machines, tablet presses, bottling production lines, and packaging machines, etc,

The service network covers the globe and is widely recognized for its quality and performance. On a modern production base covering an area of 5000 square meters, wisdom and innovation are intertwined, 85 elite talents jointly build their dreams. We have passed the ISO9001 quality management system certification, and our products have all obtained the EU CE certification, with excellent quality and steady progress.

温州大格机械科技有限公司坐落于中国工业名城温州，扎根于机械制造的沃土。公司专注于制药和包装机械领域，历经二十三载春秋，精益求精，已然成为行业翘楚。

大格机械如同机械行业的一艘巨舰，旗下产品繁多，涵盖液体灌装封口机、泡罩包装机、胶囊填充机、装盒机、研磨机、造粒机、干燥机、混合机、压片机、瓶装生产线及封装机等，服务网络遍及全球，质量和性能得到广泛认可。

在占地5000平方米的现代化生产基地上，智慧与创新交织，85位精英才俊共筑梦想。

我们通过了ISO9001质量管理体系认证，产品均获欧盟CE认证，品质卓越，行稳致远。大格机械以质量为基石，性能为脊梁，服务为翅膀，赢得了全球160多个国家和地区客户的信赖与支持。

我们的足迹遍布中国、亚洲、欧洲、美洲、中东和非洲，客户的满意与信任，成为我们不断前行的动力。

我们诚邀四海宾朋莅临参观，交流合作，共襄盛举。

在大格机械，我们不仅制造机械，更致力于通过科技与创新，为世界打造更加美好的生活，

正如我们的愿景一样——让生活更简便，让人类更健康。



PRODUCT DISPLAY

产品展示

一站式服务



WORKSHOP PLANNING

生产车间规划方案

一站式服务



方案说明：本方案旨在帮助客户实现制剂车间规划，实现车间集成化、智能化、信息化生产运作，保证了产品的可控性和一致性，最终实现自动化的生产。

设计方法：按照客户所有的车间总图和设备要求（即生产的产品和产量需求），进行整套车间的规划和预算。

工艺流程：标准的车间工艺流程为：车间净化—水处理—配液—包材整理清洗杀菌—灌装封口—后道包装，此流程可按客户的产品要求进行重新设计和规划。

Program description: This program aims to help customers realize the preparation workshop planning, realize the workshop integrated, intelligent and information-based production operation, ensure the controllability and consistency of products, and finally realize the automatic production.

Design method: according to the customer's workshop layout and equipment requirements (i.e. the production of products and production requirements), the entire workshop planning and budget.

Process flow: the standard workshop process flow is: workshop purification - water treatment - liquid preparation - packing material finishing, cleaning and sterilization - filling and sealing - after packaging. This process can be redesigned and planned according to the product requirements of customers.

PRODUCT CATALOG

产品目录

一站式服务

- 01** 西林瓶粉剂洗烘灌封联动生产线
Vial Bottle Powder Filling Production Line
- 03** 西林瓶水针剂（冻干粉）洗烘灌封联动生产线
Washing, Drying, Filling And Sealing Production Line Of Water Injection (lyophilized Powder) For Vials
- 05** 5-25ml 口服液洗烘箱灌封联动生产线
5-25ml Oral Liquid Filling Production Line
- 07** 20-100ml口服液生产线
20-100ml Oral Liquid Filling Production Line
- 09** 20-100ml高速口服液生产线
20-100ml Oral Liquid Filling Production Line
- 11** 大输液、疫苗生产线
Big Infusion, Vaccine Bottle Production Line
- 13** 塑料瓶灌装生产线
Plastic Bottle Filling Production Line
- 15** 滴眼剂生产线
Eye Drops Production Line
- 17** 喷雾剂生产线
Spray Production Line
- 19** 凝胶推杆组合灌装生产线
Gel Filling Combination Machine
- 21** 粉散剂生产线
Powderproduction Line
- 22** 开塞露生产线系列
Suppositories Glycerol Production Line
- 23** 片、胶、丸数粒瓶包装生产线
Pill Capsule Counting Production Line
- 24** 管制瓶、泡腾片瓶装生产线
Tube Type Bottle、 Effervesce Tablets Bottle Production Line
- 25** 供瓶、理瓶系列
Bottle Feeder/unscrambler Series
- 27** 洗瓶机系列
Washing Bottle Series
- 31** 隧道烘箱系列
Drying Sterilization Over Series
- 33** 灌装机系列
Filling Machine Series
- 45** 旋盖、轧盖机系列
Capping Machine Series
- 47** 贴标机系列
Labeling Machine Series
- 50** 包装机系列
Packing Machine Series
- 51** 终端灭菌系列
Terminal Sterilization Series

西林瓶粉剂洗烘灌封联动生产线

Vial Bottle Powder Filling Production Line

设备简介

- ◎本生产线适用于西林瓶洗瓶、干燥灭菌、粉剂分装加塞、轧盖；广泛运用于药品、生物制剂、保健品等。
- ◎本线由 SGLCX型立式超声波洗瓶机、SGRHX型热风循环隧道式烘箱、SGFJ型粉剂分装加塞机SGZG型轧盖机构成；整线可联动使用也可单机使用；
- ◎根据用户工艺要求配置设备可满足不同规格、不同产能的生产需要。

Equipment Brief introduction

- ◎This production line suitable for Vial washing, Dry and sterilization, Powder filling and stoppering, Capping(roll); Widely use for drugs, Biologics agents, Health products etc.
- ◎Production line composed by SGLCX Vertical ultrasonic washing machine SGRHX Hot air circulation tunnel oven, SGFJ Powder filling and stoppering machine, SGZG Capping(roll) machine; Can be connected for production line or stand-alone.
- ◎According to customer technological requirements configuration can satisfy different specifications and production speed.

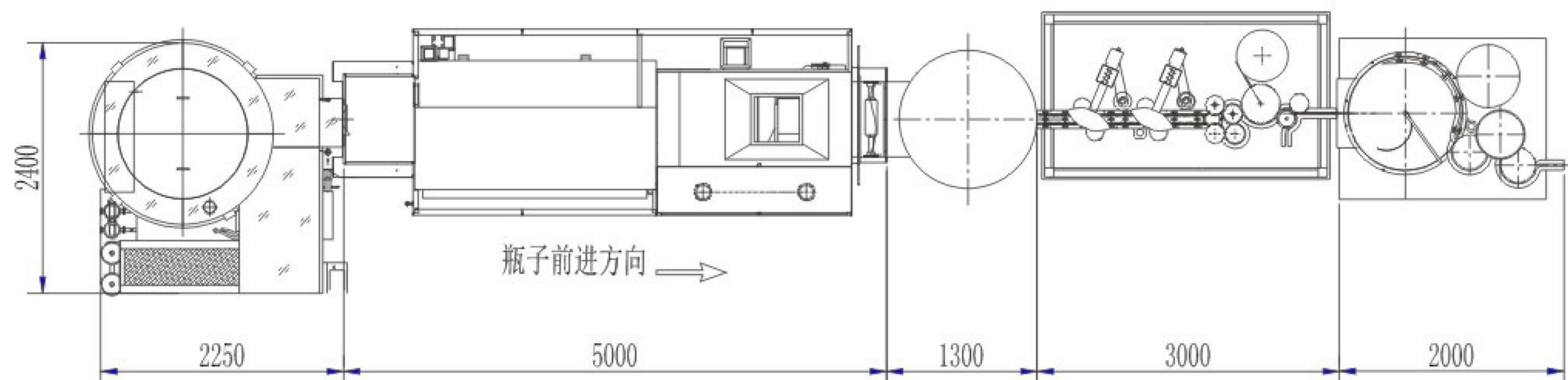

技术参数 Technical Parameters:

产品型号 Product No	SGFJ-2	SGFJ-4	SGFJ-6
适用规格 Applicable specification	0.1-3g	0.1-3g	0.1-3g
生产能力 Production speed	60-100瓶/分(b/m)	120-200瓶/分(b/m)	200-300瓶/分(b/m)
装量误差 Filling error	±3%	±3%	±3%
水压及耗水量 Water pressure and water consumption	0.25-0.35mpa,0.5-5m ³ /h	0.25-0.35mpa,0.5-8m ³ /h	0.25-0.35mpa,0.5-8m ³ /h
电源 Power supply	380/220v,45KW	380/220V,85KW	380/220v,85KW
净化压缩空气气压及耗气量 Purify compressed air pressure and air consumption	0.6-0.8mpa,5~15m ³ /h	0.6-0.8mpa,30-45m ³ /h	0.6-0.8mpa,30-45m ³ /h
排风量 Exhaust volume	2800m ³ /h	3200m ³ /h	3200m ³ /h
重量 Weight	4000KG	8000KG	12000KG
外形尺寸 Dimensions	10000 × 1800 × 1800mm	12000 × 12500 × 2400mm	12000 × 2500 × 2400mm

西林瓶水针剂（冻干粉）洗烘灌封联动生产线

Washing, drying, filling and sealing production line of water injection (lyophilized powder) for vials



设备简介

- 本线主要用于西林瓶冻干粉的液体灌装生产动作，由超声波洗瓶机、隧道烘干灭菌机、自动灌装半加塞机，自动轧盖机，贴标机等组成；
- 可完成西林瓶清洗、烘干灭菌、液体灌装半加塞机，自动轧盖和贴标等生产动作，整线联控控制，符合制药生产要求；
- 可按客户工艺及产量要求进行设备配置升级改造。

Equipment Brief introduction

- This line mainly use for vial bottle freeze-dried powder's liquid filling, It's made up of ultrasonic bottle washing machine, tunnel drying sterilizer, automatic filling half-stoppering machine, automatic sealing machine, labeling machine.
- It can finished vial bottle washing, drying and sterilizer, liquid filling and half-stoppering, automatic sealing and labeling, the whole line interlocking control conforms to the requirements of the pharmaceutical production.
- It can according to customer technology and production requirements, equipment upgrading and upgrading.

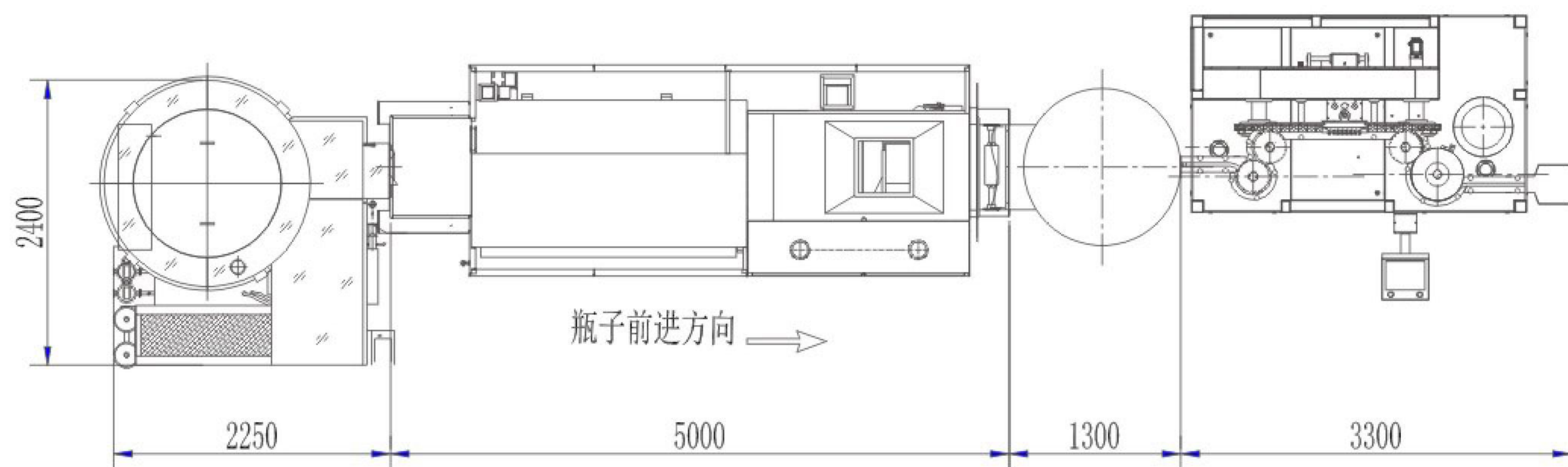

技术参数 Technical Parameters

产品型号 Product No	SGXY-4	SGXY-6	SGXY-8	SGXY-12
适用规格 Applicable specification	0.5-5ml	0.5-5ml	0.5-5ml	0.5-5ml
装量误差 Filling error	± 1%	± 1%	± 1%	± 1%
生产能力 Production speed	80-120瓶/分(b/m)	150-250瓶/分(b/m)	200-300瓶/分(b/m)	300-400瓶/分(b/m)
气压及耗气量 Air pressure and air consumption	0.5-0.8MPa, 40-50m³/h	0.5-0.8MPa, 50-60m³/h	0.5-0.8Ma, 70-80m³/h	0.5-0.8Ma, 70-80m³/h
水压及耗水量 Water pressure and water consumption	0.3-0.4MPa, 0.5-5.0m³/h	0.3-0.4MPa, 0.5-8.0m³/h	0.3-0.4MPa, 0.5-8.0m³/h	0.3-0.4MPa, 0.5-8.0m³/h
电源 Power supply	380/220V, 60KW	380/220v, 90kW	380/220V, 90KW	380/220V, 90KW
排风量 Exhaust air volume	3000m³/h	3500m³/h	3500m³/H	3500m³/H
整线重量 Whole line weight	8500KG	10000KG	12000KG	12000KG
尺寸 Dimensions	12000*1800*1800	14000*1800*1800	16000*1800*1800	16000*1800*1800

5-25ml 口服液洗烘箱灌封联动生产线

5-25ml Oral Liquid Filling Production Line



设备简介

- 生产线适用于5-25ml管制瓶口服液洗烘灌轧。由SGLCX立式超声波洗瓶机、SGRHX热风循环隧道烘箱、SGKGZ系列口服液灌装轧盖机组成生产联动线。可连线生产亦可单机使用；
- 工艺流程为：网带进瓶、超声波清洗、三水三气内冲外淋、干燥灭菌、灌装轧盖；
- 生产线性能稳定，操作简单可靠，根据用户工艺要求配置可满足不同规格、不同产能的生产需要。

Equipment Brief introduction

- This production line suitable for 5-25ml tube-type bottle oral liquid Washing, Drying, Filling and capping(Roll). Production line composed by SGLCX Vertical ultrasonic wave washing machine, SGRHX Hot air circulation tunnel oven, SGKGZ Oral liquid filling capping(roll) machine. Can use production line or stand-alone;
- The technological process: Mesh belt into bottle, Ultrasonic wave washing, Three times water and air clean bottle inside and outside, Dry and sterilization, Filling and capping(roll);
- This production line performance stable, operation is very simple, According to customer technological requirements configuration can satisfy different specifications and production speed.

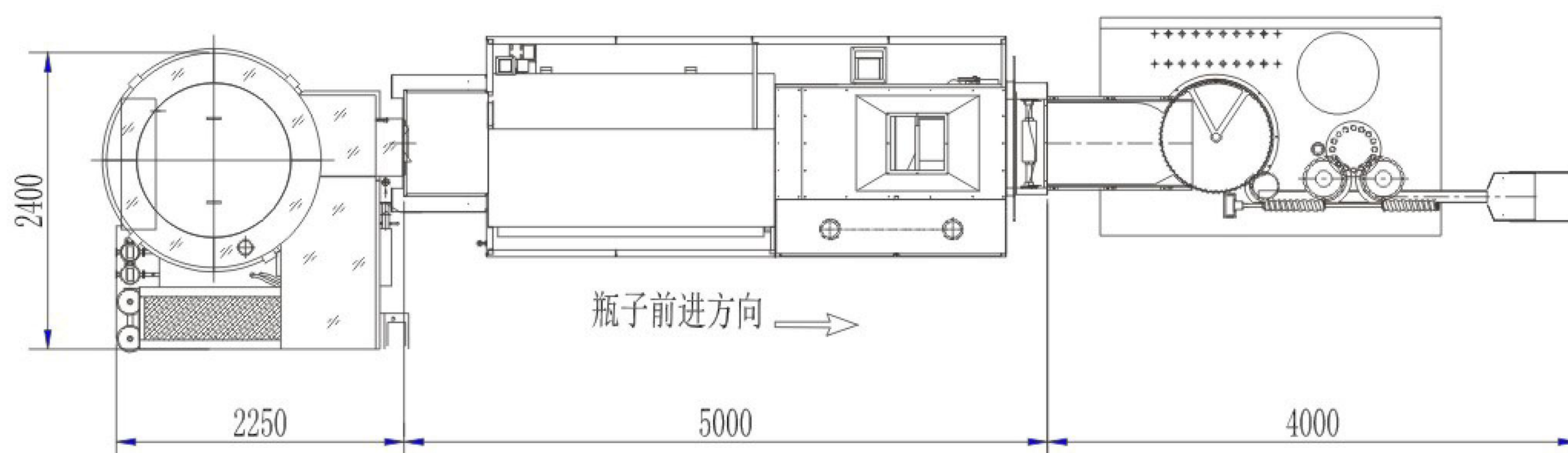

技术参数 Technical Parameters

产品型号 Product No	SGKGZ-4	SGKGZ-12	SGKGZ-16
适用规格 Applicable specification	5-25ml	5-25ml	5-25ml
生产能力 Production speed	60-80瓶/分(b/m)	150-220瓶/分(b/m)	300-350瓶/分(b/m)
装量误差 Filling error	± 1~2%	± 1~2%	± 1~2%
水压及耗水量 Water pressure and water consumption	0.25-0.35MPa, 0.5m³/h	0.25-0.35MPa, 1.5m³/h	0.25-0.35MPa, 0.5m³/h
电源 Power supply	380/220V, 8KW	380/220V, 42KW	380/220V, 80KW
净化压缩空气气压及耗气量 Purify compressed air pressure and air consumption	0.3-0.5MPa, 10m³/h	0.3-0.5MPa, 5-15m³/h	0.3-0.5MPa, 30-45m³/h
排风量 Exhaust volume	/	2600m³/h	3200m³/h
重量 Weight	650KG	3000KG	7500KG
外形尺寸 Dimensions	4000 × 1300 × 1500mm	11000 × 1800 × 2000mm	12000 × 2500 × 2400mm

20-100ml口服液生产线

20-100ml Oral Liquid Filling Production Line

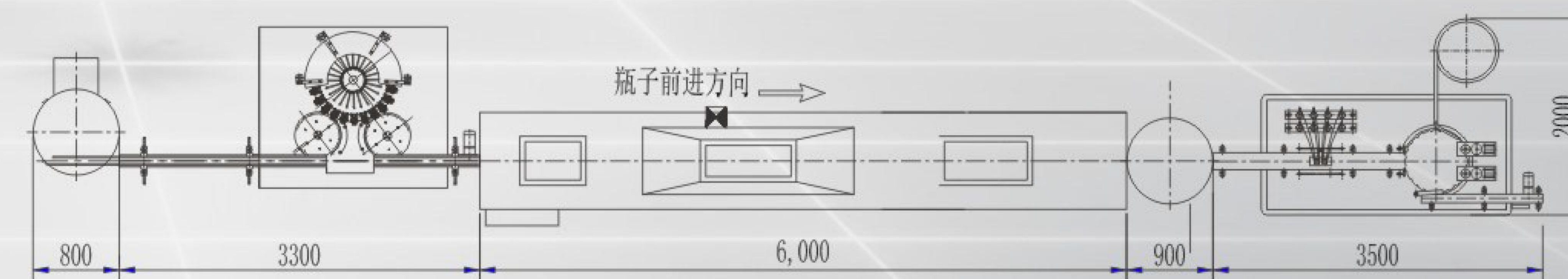
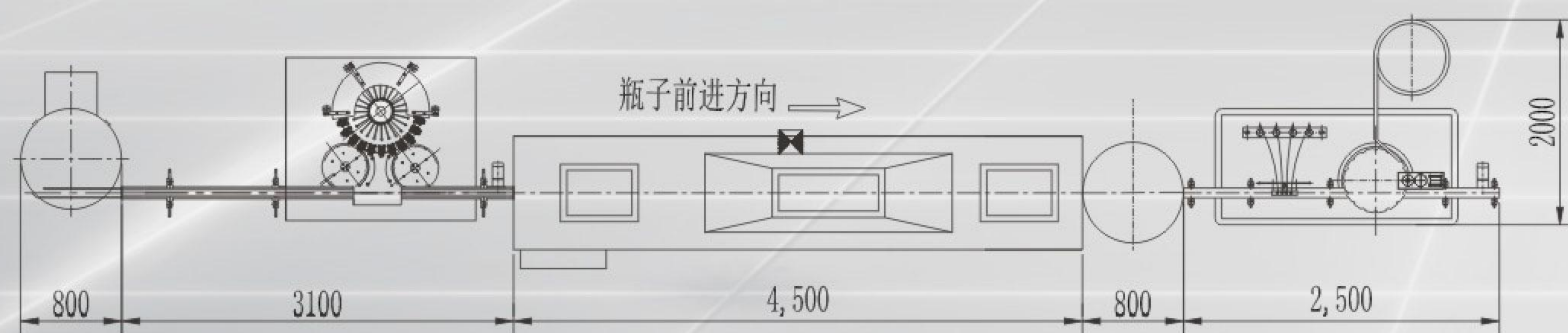

设备简介

- 生产线适用于20-100ml金属螺纹盖玻璃瓶口服液洗烘灌装。
- 由洗瓶机、隧道式烘箱、液体灌装轧盖机组成生产联动线。可连线生产亦可单机使用；
- 工艺流程为：洗瓶、干燥灭菌、灌装轧盖；
- 广泛运用于玻璃瓶口服液，尤其轧螺纹盖装置为我司专利结构，螺口光整平滑，设备性能稳定，操作简单可靠；
- 根据用户工艺要求配置可满足不同规格、不同产能的生产需要。

Equipment Brief introduction

- This production line suitable for 20-100ml metal screw thread cap glass bottle oral liquid Washing, Drying, Filling and capping(Roll).
- Production line composed by Washing machine, Tunnel oven, Liquid filling and capping(roll) machine, Can be connected for production line or stand-alone.
- The technological process: Bottle feeding, Washing bottle, Dry and sterilization, Filling and capping(roll).
- Widely used in glass bottles of oral liquid, especially capping(roll) metal screw thread cap is our company patent structure, screw thread neat and smooth, Equipment performance stable, Operation is very simple.
- According to customer technological requirements configuration can satisfy different specifications and production speed.

技术参数 Technical Parameters

产品型号 Product No	SGGZ-4	SGGZ-8
适用规格 Applicable specification	20-100ml	20-100ml
生产能力 Production speed	40-60瓶/分 (b/m)	80-120瓶/分 (b/m)
装量误差 Filling error	± 1~2%	± 1~2%
水压及耗水量 Water pressure and water consumption	0.3-0.5mpa, 0.6~1m ³ /h	0.3-0.5MPa, 0.6~1m ³ /h
电源 Power supply	380/220v, 42.5KW	380/220V, 45KW
净化压缩空气气压及耗气量 Purify compressed air pressure and air consumption	0.6-0.8mpa, 10~45m ³ /h	0.3-0.8MPa, 10~45m ³ /h
排风量 Exhaust volume	2600m ³ /h	2800m ³ /h
重量 Weight	5000KG	6000KG
外形尺寸 Dimensions	11000 × 1550 × 2000mm	15000 × 1750 × 2000mm

20-100ml高速口服液生产线

20-100ml Oral Liquid Filling Production Line

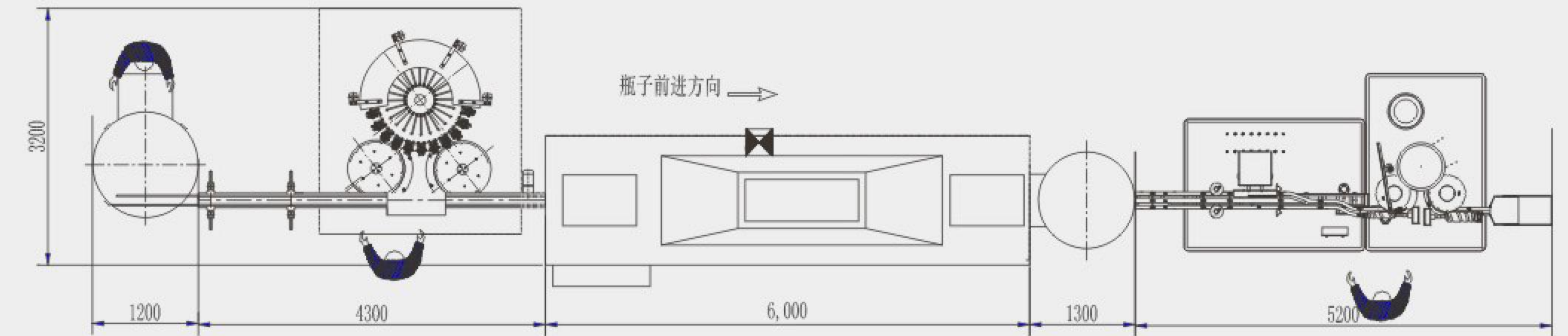

设备简介

- 生产线适用于20-100ml金属螺纹盖玻璃瓶口服液洗烘灌装。
- 由洗瓶机、隧道式烘箱、液体灌装轧盖机组成生产联动线，可连接生产亦可单机使用。
- 工艺流程为：洗瓶、干燥灭菌、灌装轧盖。
- 广泛运用于玻璃瓶口服液，尤其轧螺纹盖装置为我司专利结构，螺口光整平滑，设备性能稳定，操作简单可靠。
- 根据用户工艺要求配置可满足不同规格、不同产能的生产需要。

Equipment Brief introduction

- This production line suitable for 20-100ml metal screw thread cap glass bottle oral liquid Washing, Drying, Filling and capping (Roll).
- Production line composed by Washing machine, Tunnel oven, Liquid filling and capping(roll) machine. Can be connected for production line or stand-alone
- The technological process: Washing bottle, Dry and sterilization, Filling and capping(roll).
- Widely used in glass bottles of oral liquid especially capping(roll) metal screw thread cap is our company patent structure, screw thread neat and smooth, Equipment performance stable, Operation is simple and reliable.
- According to customer technological requirements configuration can satisfy different specifications and production speed.

技术参数 Technical Parameters

产品型号 Product No	SGGZ-12
适用规格 Applicable specification	20-100ml
生产能力 Production speed	150-220瓶/分(b/m)
装量误差 Filling error	± 1~2%
水压及耗水量 Water pressure and water consumption	0.3-0.5mpa, 0.6~1.5m ³ /h
电源 Power supply	380/220v, 48KW
净化压缩空气气压及耗气量 Purify compressed air pressure and air consumption	0.6-0.8mpa, 30~60m ³ /h
排风量 Exhaust volume	3200m ³ /h
重量 Weight	8000KG
外形尺寸 Dimensions	12000 × 2500 × 2000mm

大输液、疫苗生产线

Big Infusion, Vaccine Bottle
Production Line



设备简介

- 生产线适用于30-500ml大容量液体生产，适用于输液、疫苗、油乳剂等产品。即可用于玻璃瓶也适用于塑料瓶；
- 本线由SGGP型供瓶机、SGGCX滚筒式超声波洗瓶机、SGGS型灌装加塞机、SGZG型轧盖机构成，根据工艺要求可配置隧道式烘箱；整线可联动使用也可单机使用；
- 生产线性能稳定，操作简单可靠，根据用户工艺要求配置可满足不同规格、不同产能的生产需要。根据瓶规格不同增加规格件可兼容瓶规格。

Equipment Brief introduction

- This production line suitable for 30-500ml large volume liquid produce, Suitable for infusion, vaccine, oil emulsion etc products. Can applicable to glass bottle and also plastic bottle;
- Production line composed by SGGP Bottle feeder, SGGCX Drum type ultrasonic bottle washing machine, SGGS Filling and stoppering machine, SGZG Capping(roll) machine. According to customer technological requirements configuration can add tunnel oven; Can be connected for production line or stand-alone.
- Equipment performance stable, Operation is simple and reliable According to customer technological requirements configuration can satisfy different specifications and production speed. According to the bottles of different specifications increase accessories can compatible bottle specifications.

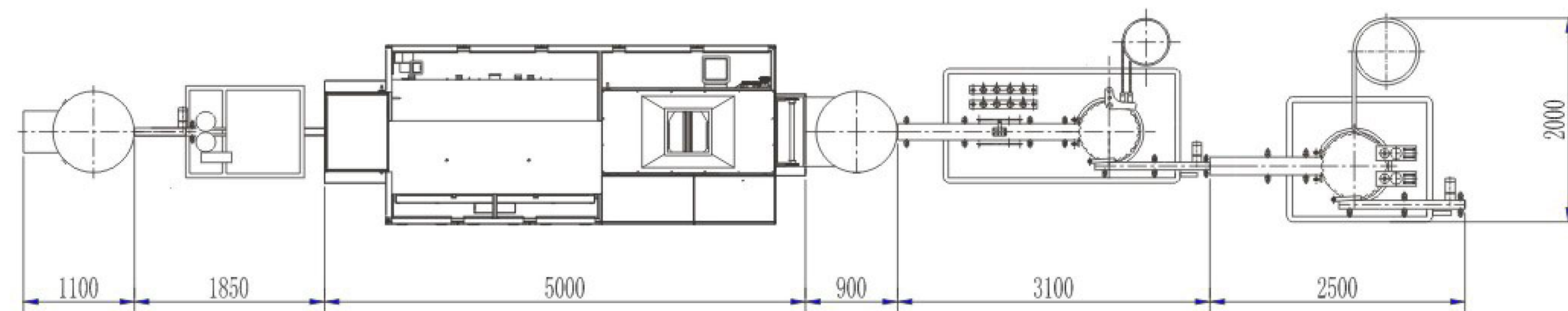
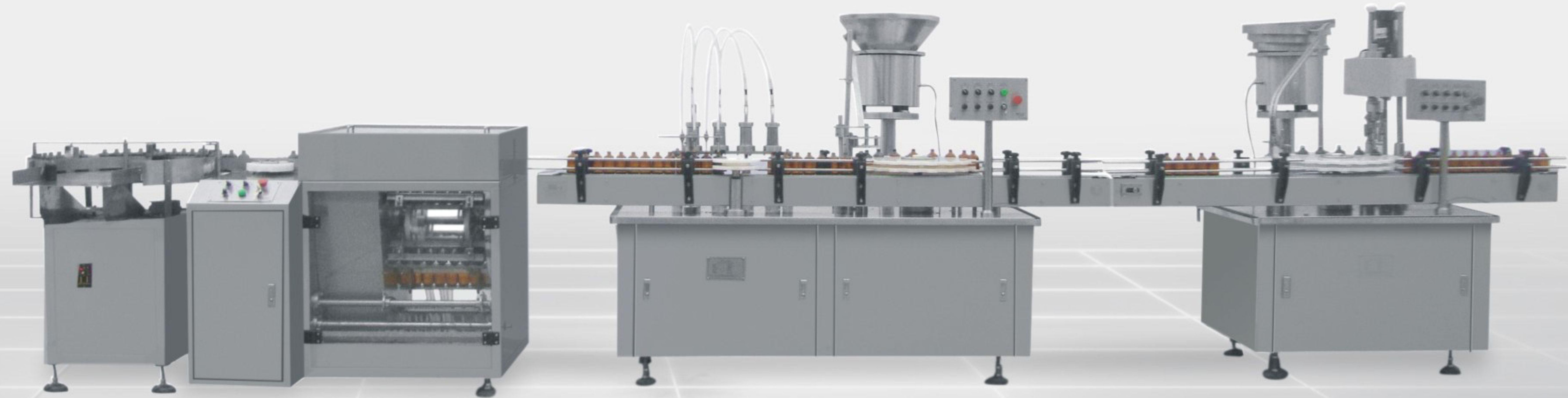

技术参数 Technical Parameters

产品型号 Product No	SGGSZ
适用规格 Applicable specification	30-500ml
生产能力 Production speed	40-60瓶/分(b/m), 80-100瓶/分(b/m)
装量误差 Filling error	± 1~2%
水压及耗水量 Water pressure and water consumption	0.3-0.5mpa, 0.6-1m³/h
电源 Power supply	380/220v, 45KW
净化压缩空气气压及耗气量 Purify compressed air pressure and air consumption	0.6-0.8mpa, 5-45m³/h
排风量 Exhaust volume	2800m³-3500m³/h
重量 Weight	6000KG
外形尺寸 Dimensions	13500x1750x2000mm

塑料瓶灌装生产线

Plastic bottle filling production line



设备简介

- 生产线适用于30-500ml大容量液体生产，适用于各类口服剂、外用剂型等品种。
- 由SGLP型理瓶机、SGGX型灌装旋盖机、SDLBF电磁感应铝箔封口机、SGLT型贴标机构成；整线完成自动瓶整理，灌装旋盖，封口贴标；根据用户的工艺要求可优化配置，如异形瓶的人工上瓶，塑料瓶的真空气洗，圆瓶贴标及扁瓶的单双面贴标等；
- 本线设备为本公司传统产品，设备性能稳定，操作简单可靠，根据用户工艺要求配置满足不同规格、不同产能的生产需要。

Equipment Brief introduction

- This production line suitable for 30-500ml large volume liquid produce, Suitable for all kinds of oral agents, syrups agents, topical agents type etc variety.
- Production line composed by SGLP Bottle unscrambler, SGGX Filling and capping machine, SGLBF Electromagnetic induction aluminum foil sealing machine, SGLT Labeling machine; The whole production line complete automatic bottle unscrambler, filling and capping, foil sealing and labeling; According to customer technological requirements can optimize configuration, Such as shaped bottle's artificial arranging bottle, plastic bottle's vacuum air washing round bottle labeling and flat bottle's double side labeling etc.
- This production line is our Shengguan company traditional products Equipment performance stable, Operation is very simple, According to customer technological requirements configuration can satisfy different specifications and production speed.

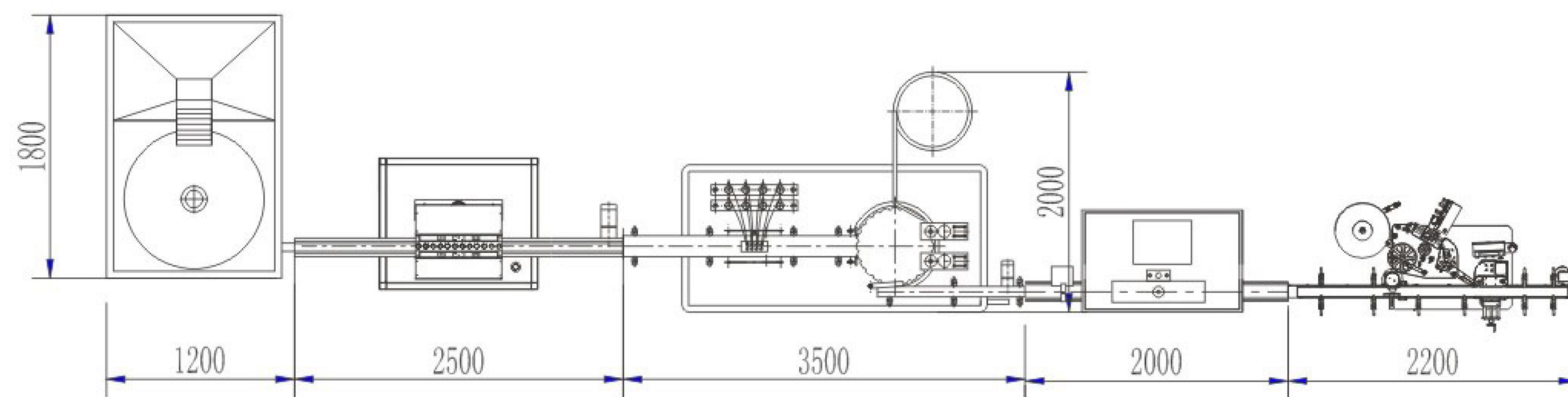
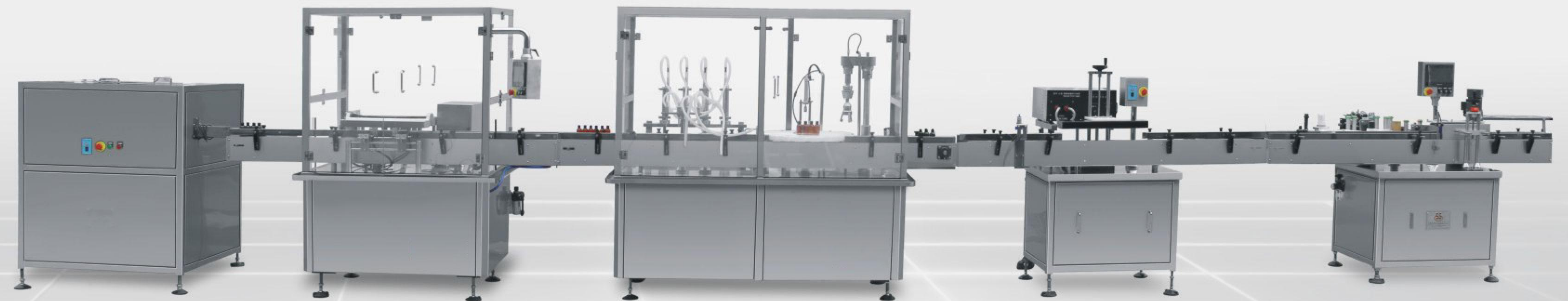

技术参数 Technical Parameters

产品型号 Product No	SGGX-4	SGGX-8	SGGX-12
适用规格 Applicable specification	30-500ml	30-500ml	30-500ml
生产能力 Production speed	40-60瓶/分 (b/m)	80-120瓶/分 (b/m)	150-220瓶/分 (b/m)
装量误差 Filling error	± 1~2%	± 1~2%	± 1~2%
电源 Power supply	380/220v, 8.5KW	380/220v, 9KW	380/220v, 12KW
净化压缩空气气压及耗气量 Purify compressed air pressure and air consumption	根据需求配置 According to customer technological requirements		
重量 Weight	2000KG	2000KG	4000KG
外形尺寸 Dimensions	8000 × 1650 × 1750mm	8000 × 1650 × 1750mm	12000 × 2000 × 1750mm

滴眼剂生产线

Eye Drops Production Line



设备简介

本生产线适用于滴眼剂以及各类包材瓶、塞、盖三件套，本线完成自动理瓶、溶液灌装、机械手加塞加盖、旋盖动作；根据用户的不同需要可增加理瓶或供瓶；有效完成上瓶、无瓶不灌装、无瓶不加塞、无塞不加盖；本机由圣灌技术团队对加塞盖结构升级，加塞加盖结构采用机械手方式，对位精准，成品合格率达到99.9%以上。设备性能稳定可靠。根据包材可定制，增加隔离保护系统可完成无菌滴眼剂生产。根据用户工艺要求配置可满足不同瓶规格，不同产能要求。

Equipment Brief introduction

Filling stoppering and capping machine suitable for eyedrops and all kinds of bottle packaging, stoppering, capping three-piece this machine complete automatic liquid filling, manipulator add stoppering and cap, capping; According to customer technologic requirements configuration can add bottle feeder or Unscrambler; Effective completion bottle sending, No bottle no filling, No bottle no add stoppering, No stoppering no add cap; The machine stoppering and add cap structure upgrading by Shengguan company technical team, stoppering and add cap structure use manipulator, precise alignment, finished pass rate more than 99.9%. This machine performance stable. According packaging materials can be customized, Increase isolation protection system can complete aseptic produce. According to customer technological requirements configuration can satisfy different specifications and production speed.

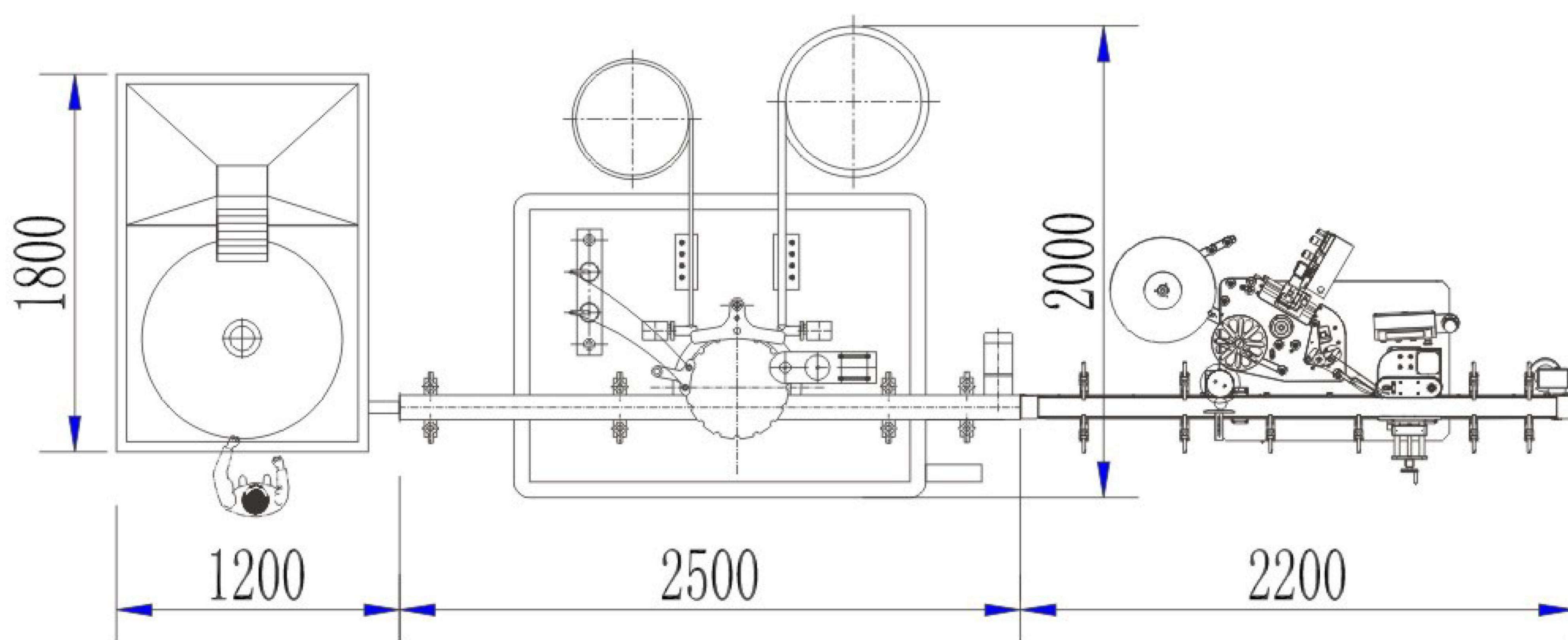
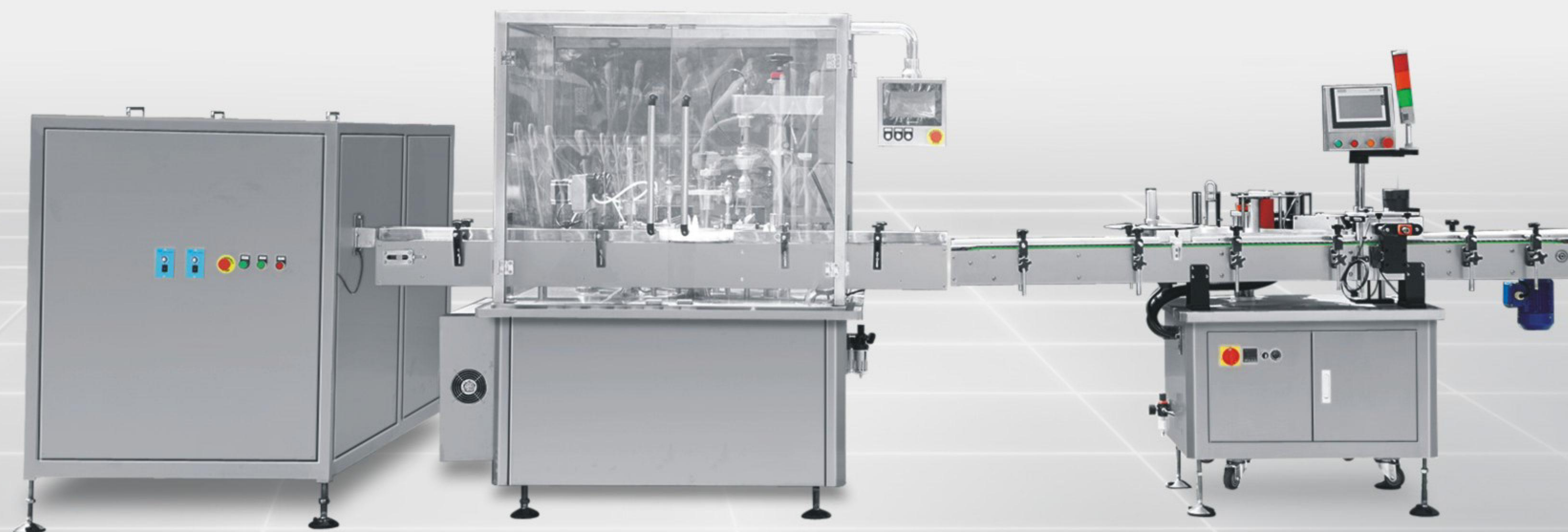

技术参数 Technical Parameters

产品型号 Product No	SGLP+SGDYJ
适用规格 Applicable specification	2-20ml
生产能力 Production speed	单头：40-55瓶/分 Single head: 40-55 (b/m) 双头：60-100瓶/分 Double head: 60-100 (b/m)
加塞盖合格率 Stoppering and add cap pass rate	>99%
装量误差 Filling error	± 1~2%
电容量 Power supply	220/380V, 2.5KW
净化压缩空气气压及耗气量 Purify compressed air pressure and air consumption	0.6-0.8MPa, 10-30m ³ /h
重量 Weight	950KG/1200KG
外形尺寸 Dimensions	7500 × 2000 × 1750mm

喷雾剂生产线

Spray Production Line



设备简介

- 本生产线适用于5-250ml等容量喷雾剂瓶的自动理瓶或供瓶，自动溶液灌装、自动加泵头、根据泵头类型可增加预旋盖结构然后进入旋盖。
- 本机为本公司传统设备，使用客户广，生产线性能稳定，操作简单可靠，根据用户工艺要求配置可满足不同规格、不同产能的生产需要。
- 根据瓶规格不同增加规格件可兼容瓶规格。

Equipment Brief introduction

- Sprays production line suitable for 5-250ml etc volume bottle automatic bottle unscrambler or bottle feeder, automatic filling liquid, automatic add cap. According to cap type can add Pre-capping structure and then into capping structure.
- This machine is Shengguan's traditional equipment, production line performance stable, operation is very simple. According to customer technological requirements configuration can satisfy different specifications and production speed.
- According to the bottles of different specifications increase accessories can compatible bottle specifications.

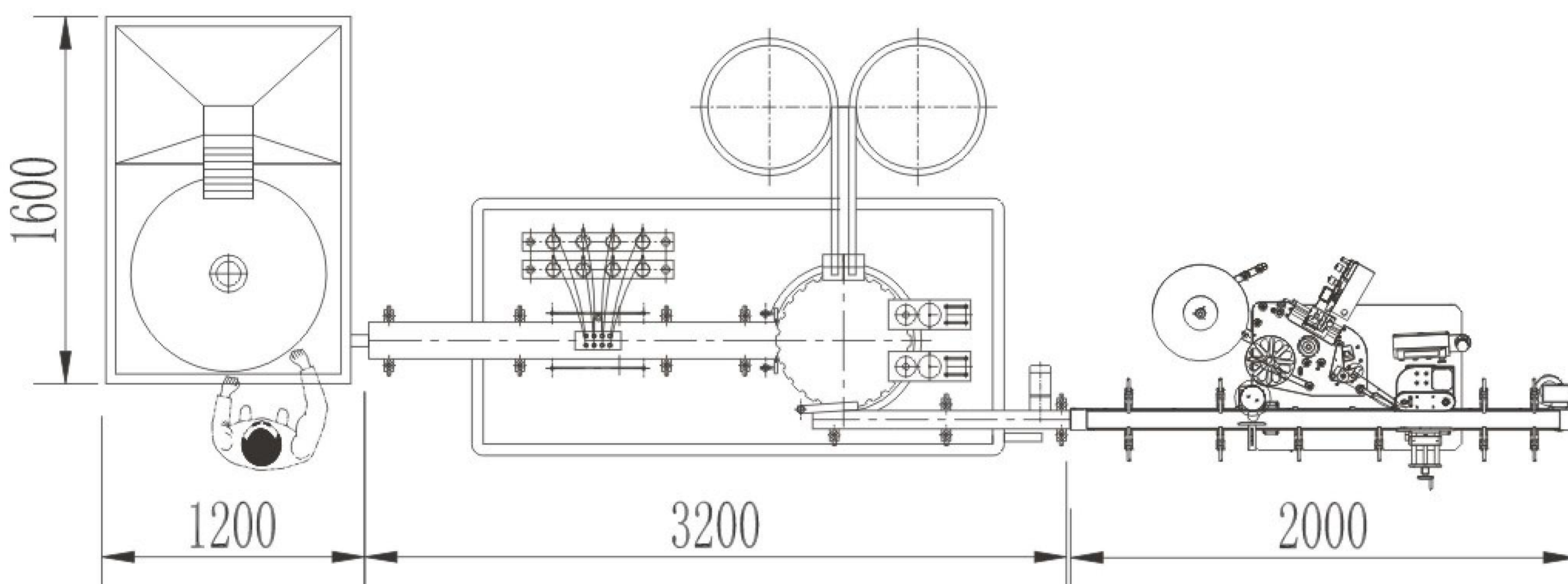

技术参数 Technical Parameters

产品型号 Product No	SGPWJ
适用规格 Applicable specification	5-250ml
生产能力 Production speed	单头: 30-60瓶/分 Single head: 30-60 (b/m) 双头: 50-120瓶/分 Double head: 50-120 (b/m)
加塞盖合格率 Stoppering and add cap pass rate	>99%
装量误差 Filling error	± 1~2%
电容量 Power supply	220/380V, 3KW
净化压缩空气气压及耗气量 Purify compressed air pressure and air consumption	0.6-0.8MPa, 10-30m³/h
重量 Weight	1500KG, 2500KG
外形尺寸 Dimensions	8000 × 2000 × 1750mm

凝胶推杆组合灌装生产线

Gel filling combination machine



GRAND
MACHINERY TECHNOLOGY
大格机械

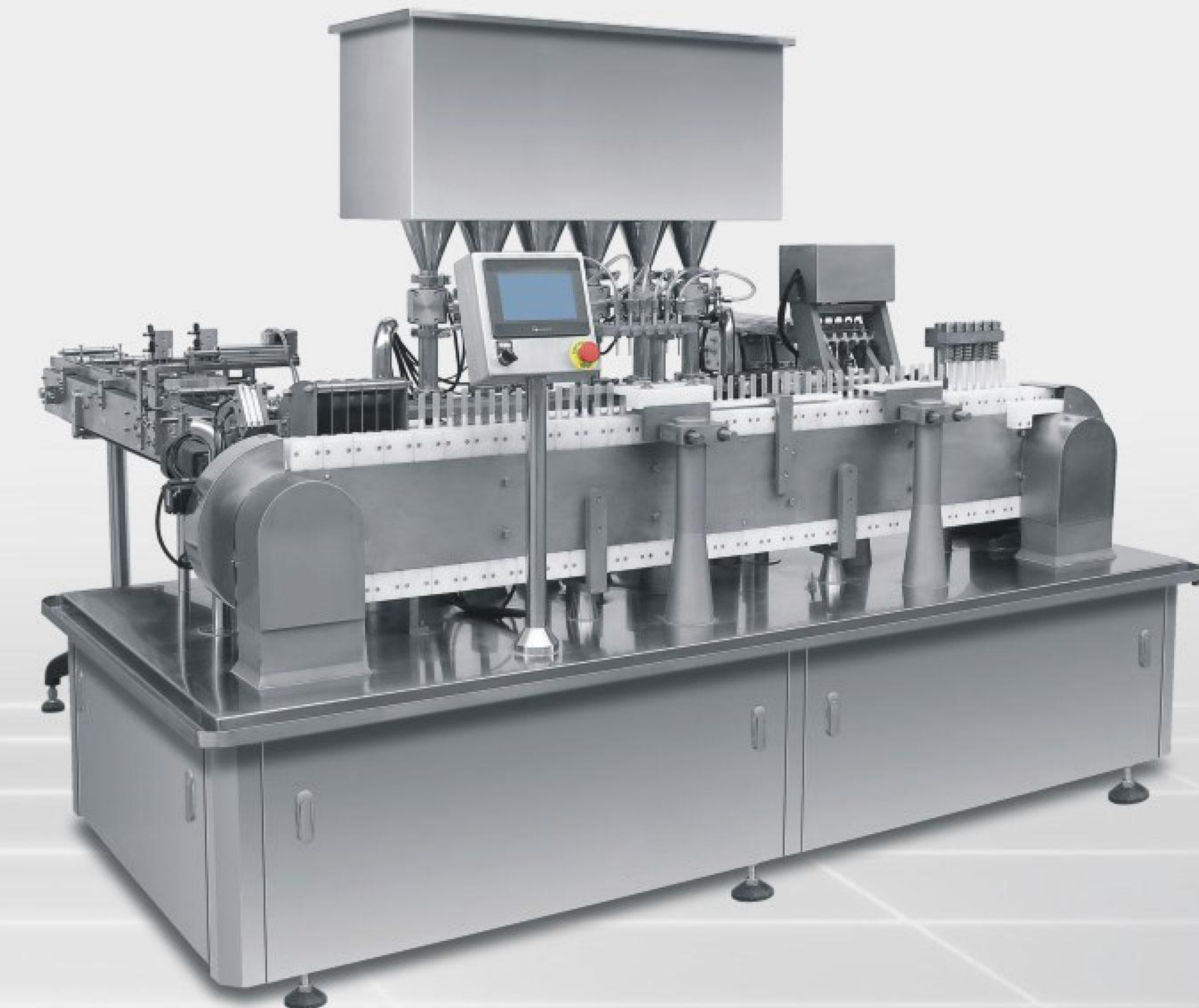

设备简介

- ◎该机组具有自动套管组合；自动翻杆进主机、灌装(有管灌装，无管不灌装)、加盖、压盖等功能。
- ◎本机组为圣灌技术团队针对医药妇科凝胶客户定制的一款设备，目前使用客户已超过30多家。
- ◎本机组除凝胶产品外还适用于药膏、化妆品、胶水、乳胶等产品的灌装生产，对于特殊的包装物料管，本公司还可专门设计定制。

Equipment Brief introduction

- ◎This machine has automatic sleeve tube combination function;Automatically turning the rod into the host,Filling(no tube on filling),Add cap,Press cap etc function.
- ◎This machine is Shengguan's technical team against medicine gynecological gel client custom,Now there are more than 100 customer used this machine.
- ◎This machine also suitable for paste,glue,emulsion etc products produce,For special packaging material tube.our company can special custom design.

技术参数 Technical Parameters

产品型号 Product No	SGNJ-2/3/4	SGNJ-6
适用规格 Applicable specification	1-5g	
生产能力 Production speed	≥40-60支/分 piece/min	≥100-120支/分 piece/min
装量误差 Filling error	± 3%	
电容量 Power supply	220V, 2.5KW	
净化压缩空气气压及耗气量 Purify compressed air pressure and air consumption	0.6-0.8MPa,50-60m³/h	
重量 Weight	1000-2000KG	
外形尺寸 Dimensions	5500 × 2200 × 1750mm	3500 × 2500 × 2000mm

粉散剂生产线

Powder production line

- 西瓜霜类粉散剂设备为圣灌公司应客户需求所开发的一套完整生产线设备,由SGLP型理瓶机与SGFSJ粉散剂分装加塞加盖一体机组成生产线;
- 本线能有效进行瓶整理、单双螺杆分装、真空吸塞加塞、加盖、旋盖等生产工序;
- 整机设计合理,设备性能稳定可靠,产品已广泛运用于制药企业。

- Powder Filling machine is Shengguan company developing a complete production equipment for customer, Production line composed by SGLP Bottle unscrambler and SGFSJ Powder filling stoppering and capping machine;
- This production line can effective completion arrange bottle, Single or double screw filling, Vacuum stoppering, Add cap, Capping etc production processes;
- Whole machine design reasonable, This machine performance stable, Machine has been widely used in the pharmaceutical industry.



开塞露生产线系列

Suppositories glycerol production line



- 本线带平底的开塞露的自动化生产, 由理瓶机、自动灌装机、自动压盖机等组成, 按照产品特性, 特制针头定位灌装, 完全符合自动化生产的需求。
- 可按照客户车间及产量要求进行设备配置改造升级。

- This line can realize flat bottom suppositories glycerol automatic production, Made up of bottle unscrambler, automatic filling machine, automatic press cap machine etc, According to product characteristic, make special filling needle, Fully meet the needs of automated production.
- It can according to customer factory and output demand reform and upgrade the equipment configuration.

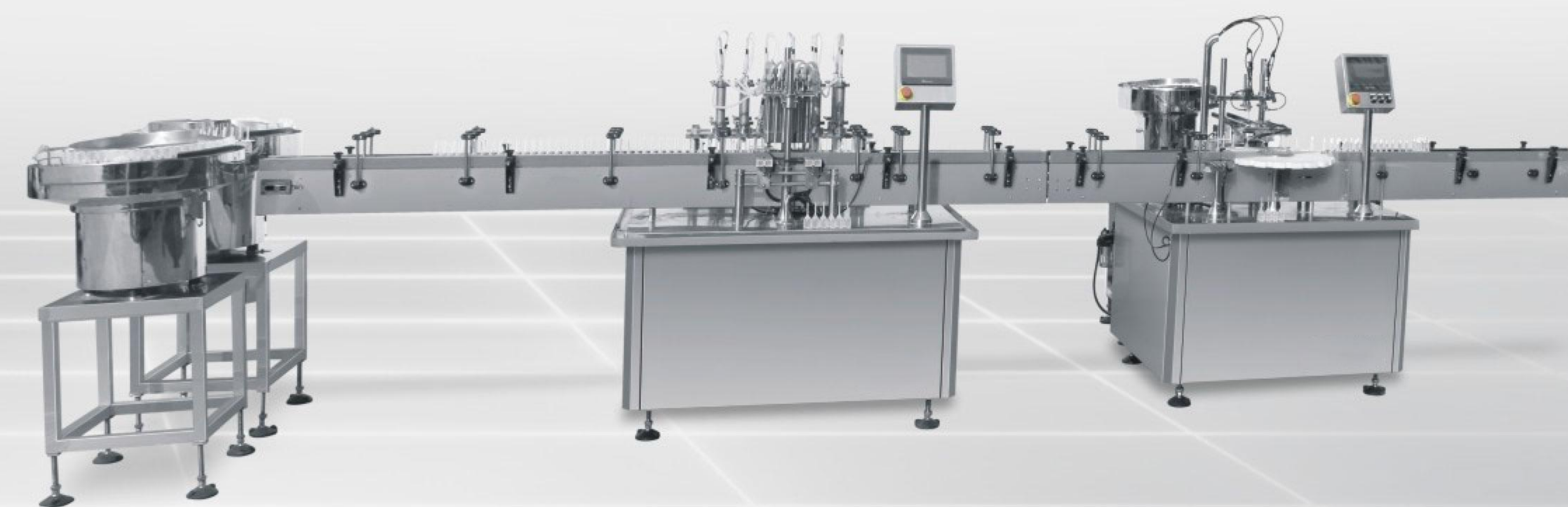

技术参数 Technical Parameters

产品型号 Product No	SGFSJ	
适用规格 Applicable specification	0.03-2g	1-10g
生产能力 Production speed	单头:35-50瓶/分 Single head:35-50b/m, 双头:50-80瓶/分 Double head:50-80b/m	
加塞盖合格率 Stoppering and add cap pass rate	>99%	
装量误差 Filling error	± 3%	
电容量 Power supply	220V3.5KW	
净化压缩空气气压及耗气量 Purify compressed air pressure and air consumption	0.6-0.8mpa, 10-30m³/h	
重量 Weight	1500kg	
外形尺寸 Dimensions	4000 × 2000 × 1750mm	5000 × 2000 × 1750mm

技术参数 Technical Parameters

产品型号 Product No	SGGY-4	SGGX-8
适用规格 Applicable specification	5-200ml	
装量误差 Filling error	± 1~2%	
生产能力 Output	40-50瓶/分 b/m	80-100瓶/分 b/m
气压及耗气量 Air pressure and air consumption	0.5-0.8MPa 10-15m³/h	0.5-0.8MPa 20-30m³/h
电源 Power supply	380/220V, 6.0KW	380/220V, 8.0KW
整线重量 Whole line weight	1500KG	1800KG
尺寸 Dimension	4500*1800*1800	6000*1800*1800

片、胶、丸数粒瓶包装生产线

Pill Capsule Counting Production Line



管制瓶、泡腾片瓶装生产线

Tube Type Bottle、Effervesce
Tablets Bottle Production Line

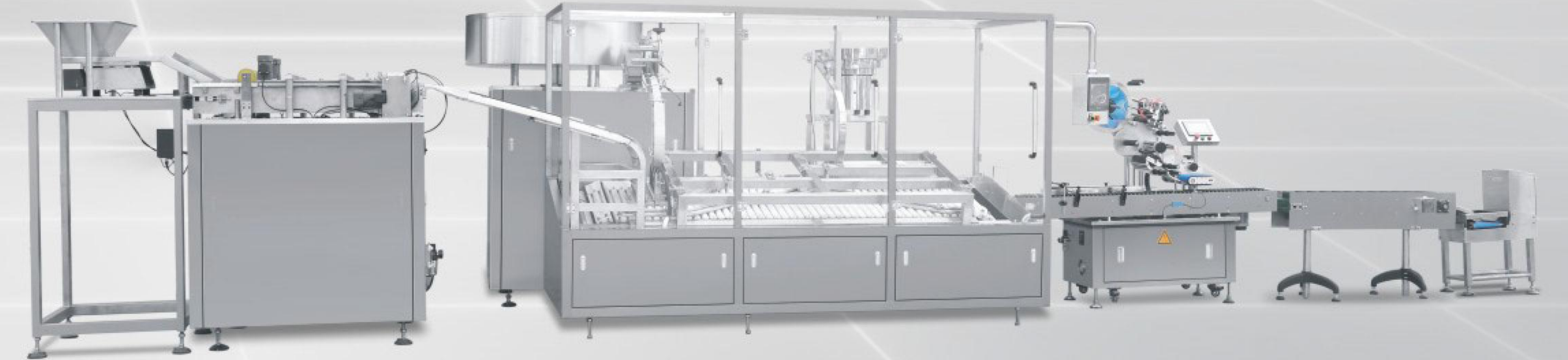

设备简介

- 数粒瓶包装生产线设备为传统设备,根据瓶型不同选配单机成线;如塑料瓶瓶包装生产线由SGLP理瓶机、SGSL型数粒机、SGSG塞干燥剂机SGXZ旋盖机、SGLBF铝箔封口机、gt立式不干胶贴标机组成;
- 如塑料管制瓶由SGGSL管制瓶数粒机完成生产要求;
- 数粒生产线设备为圣灌传统设备部,根据客户的要求可优化组合;设备性能稳定可靠,操作简单。为片剂、胶囊、丸剂包装的理想型设备。

Equipment Brief introduction

- Counting Packaging production line equipment is our company's traditional equipment, According to different bottle type choose stand-alone to production line to production line; Such as Plastic bottle packaging production line composed by SGLP Bottle unscrambler, SGSL Counting machine, SGSG Plugging drier machine, SGXZ Capping machine, SGLBF Aluminum foil sealing machine, SGLT Vertical sticker labeling machine;
- Such as plastic tube bottles composed by SGGSL Tube bottle counting machine finish production requirements;
- Counting production line equipment is our company's traditional equipment, According to customer's requirements can optimization combination This machine performance stable, operation is very simple. It's the ideal type equipment for tablet, capsule, pill etc packing.

技术参数 Technical Parameters

产品型号 Product No	SGSL	SGGSL
适用规格 Applicable specification	片剂/胶囊/丸剂Tablet/Capsule/Pill	片剂/胶囊/丸剂Tablet/Capsule/Pill
生产能力 Production speed	30-100瓶/分 b/m	30-100瓶/分b/m
电容量 Power supply	220V, 12KW	220V, 3KW
重量 Weight	2000kg	950kg
外形尺寸 Dimensions	11000 × 1500 × 1750mm	3000 × 2000 × 1750mm

供瓶缓冲系列

Bottle feeder series

本系列产品主要用于玻璃瓶生产线中理瓶和连接缓冲作用，让玻璃瓶生产线的上瓶及连线生产更加的方面，运行更加合理。

This series of products are mainly used for glass bottle production line feed bottle and connection buffering effect,let production line more convenient to run,and more reasonable.



技术参数 Technical Parameters:

产品型号 Product No	SGGP供瓶机
适用规格Applicable specification	1-1000ml
生产能力Output	满足生产线需求Meet whole production line speed
电源Power supply	220V, 0.2KW
重量Weight	150kg
尺寸Dimension	Φ600-φ1500*1200mm

理瓶机系列

Bottle unscrambler series

本系列产品主要用于塑料瓶的自动化整理，将杂乱无章的瓶子倒入理瓶斗，设备会自动将瓶子整理成口朝上进输送带，方便后续生产的使用

This series product mainly use for plastic bottle automatic sort out,Pour the disordered bottle into the machine hopper,equipment will automatic sort out, bottle will mouth upwards then go into conveyor belt, convenient follow-up production



技术参数 Technical Parameters

产品型号 Product No	SGLP型自动理瓶机
适用规格Applicable specification	1-500ml
生产能力Output	40-120瓶/分 b/m
电源Power supply	380/220V,1.0KW
重量Weight	300kg
尺寸Dimension	1800*2200*1450mm

洗瓶机系列

Washing Bottle Series



SGLCX立式超声波洗瓶机
Vertical ultrasonic bottle washing machine



SGLX螺杆式洗瓶机
Screw-type washing machine



SGJX蛟龙式洗瓶机
Auger Type Bottle Washing Machine

设备简介

由于包材的多样性以及客户对瓶清洗的要求各有不同，针对塑料瓶的真空气洗，针对玻璃瓶的超声波清洗及水气冲淋等洗瓶方式；圣灌企业针对市场需求开发的洗瓶方式也多样化。洗瓶系列产品已经广泛运用于制药、食品、日化等行业。圣灌技术团队针对客户的要求优化配置满足客户洗瓶工艺及生产能力的要求。

Equipment Brief introduction

Due to the variety of packaging and customer requirements of cleaning are different, For the plastic bottle's vacuum air washing, for the glass bottle's ultrasonic washing and water air washing etc washing bottle method; Shengguan enterprise is directed against the market requirement of washing bottle method is also developed variety of ways. Washing bottle series peoducts has been widely used in pharmaceutical, food, chemicals and other industries. Shengguan's company team optimize the configuration according to customer requirements, to meet customer requirements of washing process and production speed.

技术参数 Technical Parameters

产品型号 Product No	SGLCX立式超声波洗瓶机	SGLX螺杆式洗瓶机	SGJX蛟龙式洗瓶机
适用规格 Applicable specification	2-50ml	5-25ml	2-25ml
生产能力 Production speed	150-400瓶/分(b/m)	60-400瓶/分(b/m)	60-300瓶/分(b/m)
水压及耗水量 Water pressure and water consumption	0.3-0.5mpa,0.6~1.5m³/h	0.3-0.5mpa,0.6~1.5m³/h	0.3-0.5mpa,0.6~1.5m³/h
电源 Power supply	380/220v,2.5k	380/220v,2.5k	380/220V,2.5KW
净化压缩空气气压及耗气量 Purify. compressed air pressure and air consumption	0.6-0.8pa,30~45m³/h	0.6-0.8mpa,30~35m³/h	0.6-0.8pa,30~45m³/h
重量 Weight	2500KG	450KG	450KG
外形尺寸 Dimensions	2250 × 2250 × 1500mm	2200900 × 1350mm	2500 × 1000 × 1350mm

洗瓶机系列

Washing Bottle Series

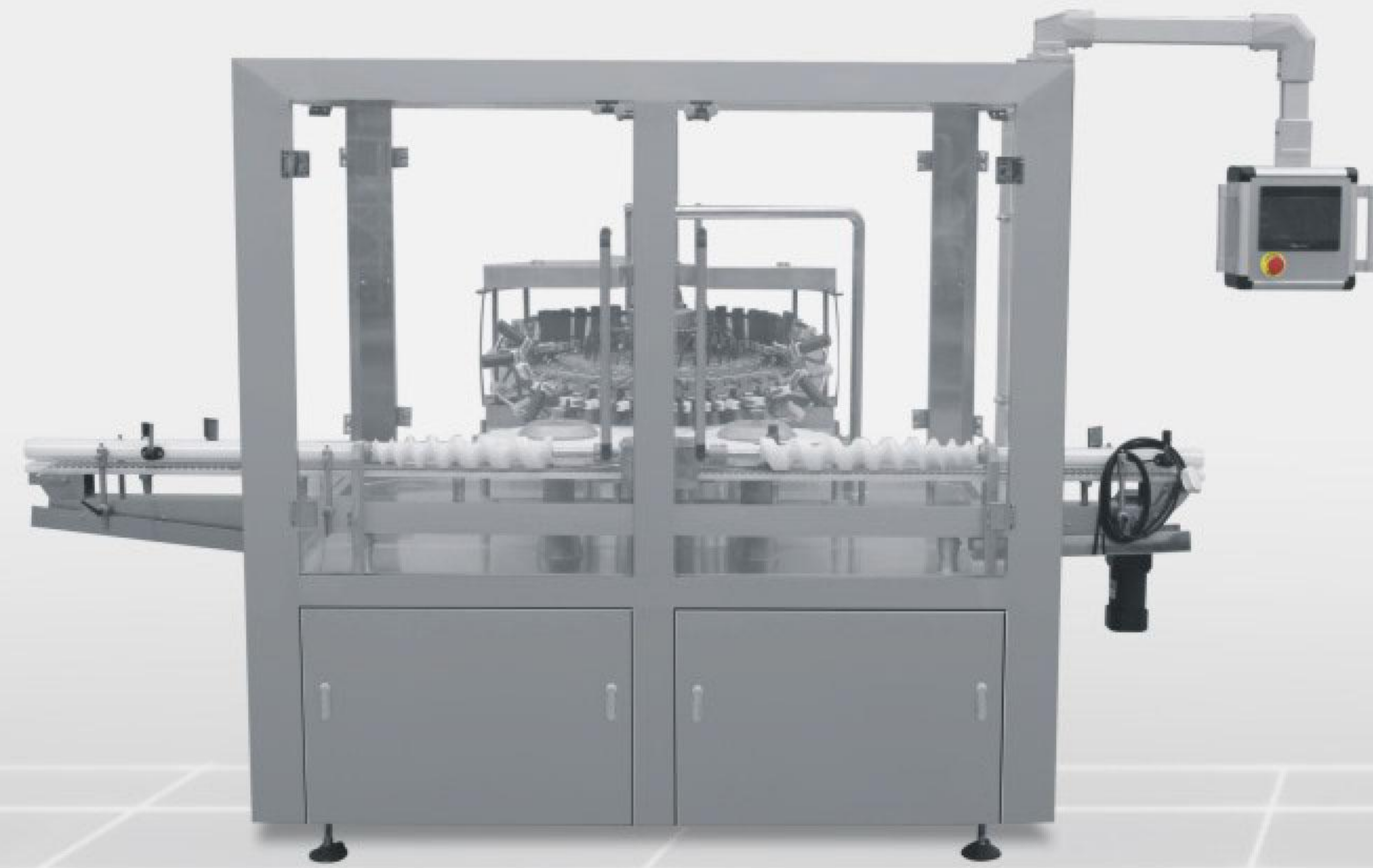

SGXX旋转式洗瓶机
Rotary type bottle washing machine

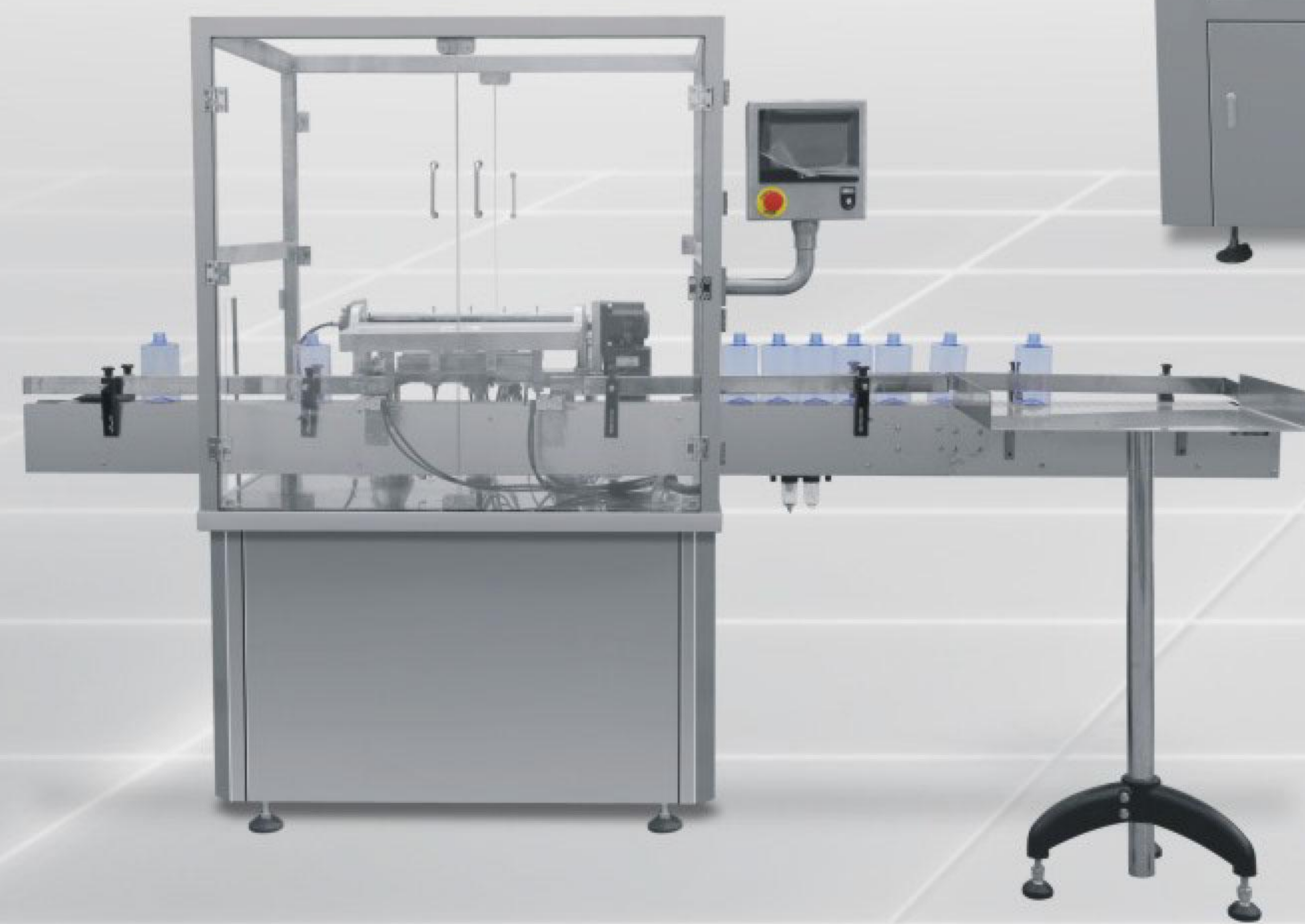

SGQX真空空气清洗机
Vacuum air washing machine

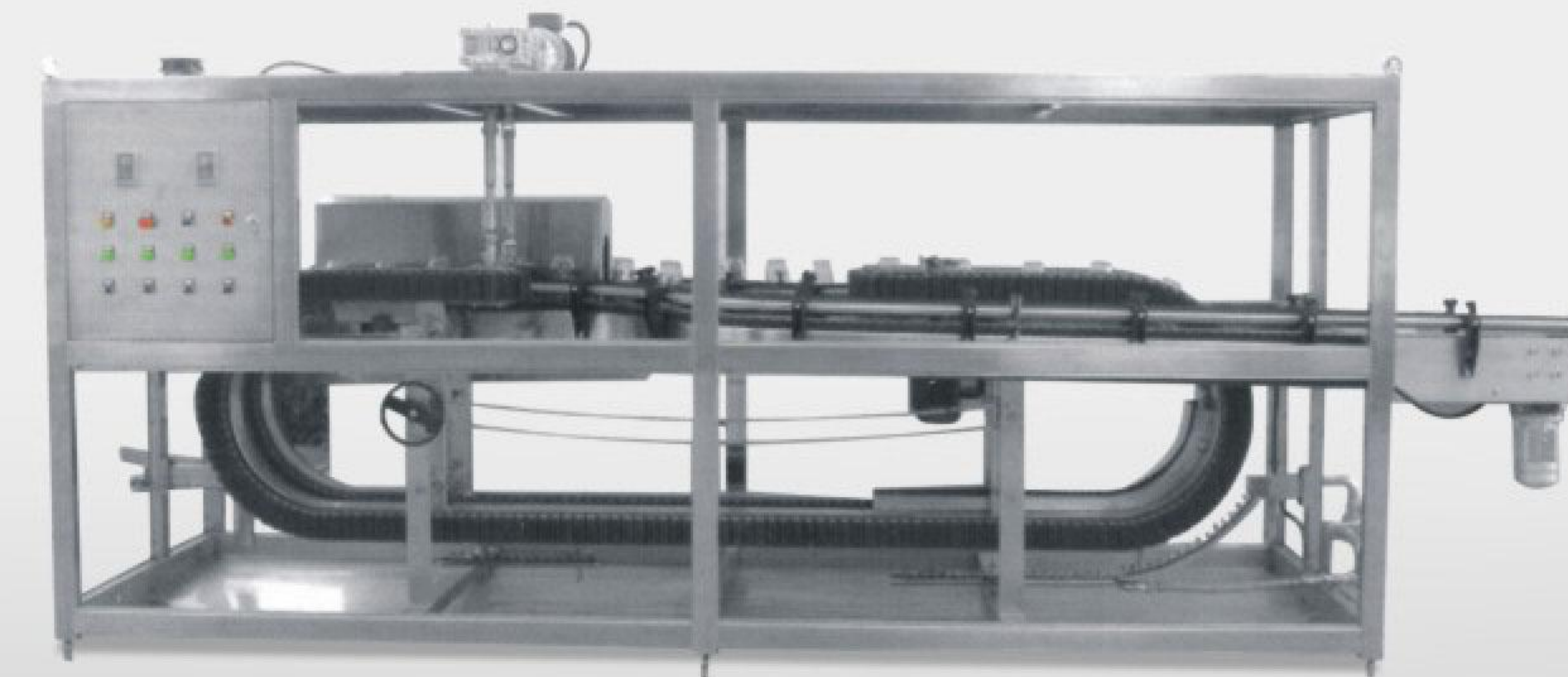

SGXP对夹式洗瓶机
Automatic multifunctional
bottle washing machine



SGGCX滚筒式超声波洗瓶机
Drum type ultrasonic bottle
washing machine

设备简介

由于包材的多样性以及客户对瓶清洗的要求各有不同，针对塑料瓶的真空空气洗，针对玻璃瓶的超声波清洗及水气冲淋等洗瓶方式；圣灌企业针对市场需求开发的洗瓶方式也多样化。洗瓶系列产品已经广泛运用于制药、食品、日化等行业。圣灌技术团队针对客户的要求优化配置满足客户洗瓶工艺及生产能力的要求。

Equipment Brief introduction

Due to the variety of packaging and customer requirements of cleaning are different, For the plastic bottle's vacuum air washing, for the glass bottle's ultrasonic washing and water air washing etc washing bottle method; Shengguan enterprise is directed against the market requirement of washing bottle method is also developed variety of ways. Washing bottle series products has been widely used in pharmaceutical, food, chemicals and other industries. Shengguan's company team optimize the configuration according to customer requirements, to meet customer requirements of washing process and production speed.

技术参数 Technical Parameters

产品型号 Product No	SGQX真空空气清洗机	SGXX旋转式洗瓶机	SGXP对夹式洗瓶机	SGGCX滚筒式超声波洗瓶机
适用规格 Applicable specification	5-500ml	20-500ml	50-1000ml	20-500ml
生产能力 Production speed	40-120瓶/分40-120b/m	60-200瓶/分60-200b/m	40-200瓶/分40-200b/m	60-120瓶/分60-120b/m
水压及耗水量 Water pressure and water consumption	/	0.3-0.5mpa,0.61.5m³/h	0.3-0.5mpa,1-2m³/h	0.3-0.5Mpa,0.61m³/h
电源 Power supply	380/220v,2kW	380/220V2.5KW	380/220V,2KW	380/220v.2.5KW
净化压缩空气气压及耗气量 Purify, compressed air pressure and air consumption	0.6-0.8mpa,30-45m³/h	0.6-0.8pa,30-45m³/h	0.6-0.8pa,30-45m³/h	0.6-0.8mpa5-15m³/h
重量 Weight	400KG	2000KG	2000kg	600kg
外形尺寸 Dimensions	2000 × 1600 × 2000mm	3500 × 1800 × 1750mm	6000 × 1750 × 2000mm	2000 × 1000 × 1350mm

隧道烘箱系列

Drying Sterilization Oven Series

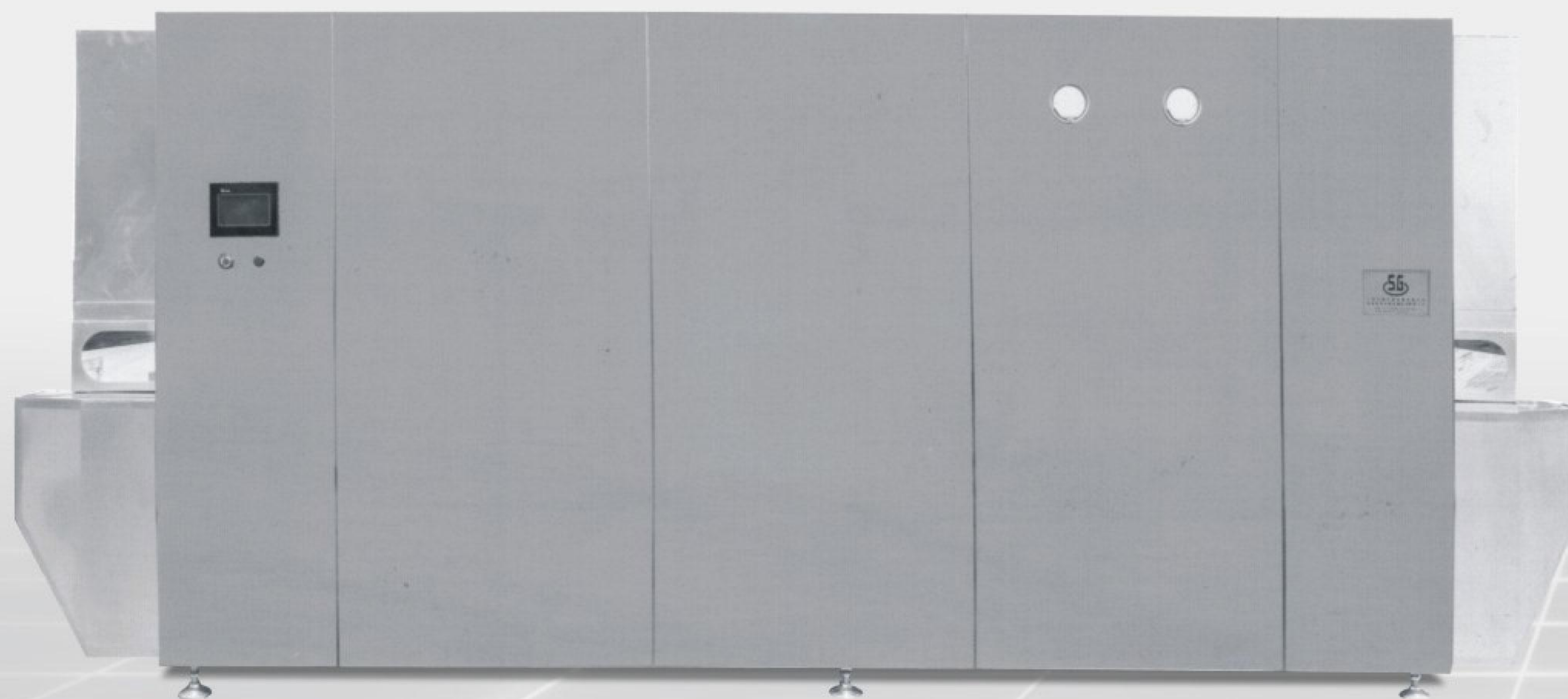

SGHX远红外隧道式烘箱
Far infrared tunnel oven



SHRHX热风循环灭菌烘箱
Hot air sterilization oven

设备简介

- ◎隧道式干燥灭菌烘箱主要运用于安瓿瓶、抗生素瓶、口服液等圆柱形玻璃瓶干燥灭菌。
- ◎瓶通过网带传输依次进入预热段、高温干燥灭菌段、冷却段的一种干燥灭菌方式,前后端设备连接组成完整联动生产线,根据用户工艺要求进行设备选型。

Equipment Brief introduction

- ◎Tunnel type dry and sterilization oven mainly used for ampoule bottle antibiotic bottle, oral bottle etc round glass bottle's dry and sterilization.
- ◎Bottle transmission by mesh belt trooped into Preheating zone, high temperature dry and sterilization zone, cool down zone, front and rear ends can connecting equipment composition production line, according to the customer process requirements to choose equipment.

技术参数 Technical Parameters

产品型号 Product No	SGHX远红外隧道式烘箱	SHRHX热风循环灭菌烘箱
适用规格 Applicable specification	适用范围:安瓿瓶、抗生素瓶、口服液等圆柱形玻璃瓶 Scope of application: Ampoule bottle, antibiotic bottle, oral bottle	
网带有效宽度 Mesh belt width	420-820mm	620mm
网带速度 Mesh belt speed	变频调速30-350mm/分钟 Frequency control: 30-350mm/min	
干燥灭菌温度 Dry and sterilization temperature	100-350°C	300-350°C
电源 Power supply	380v,36kw	380v,60kw
排风量 Exhaust volume	2600-3000m ³ /h	2800-3500m ³ /h
重量 Weight	1800Kg	3000kg
外形尺寸 Dimensions	5000 × 1300 × 2000mm	4800 × 1650 × 2400mm



SGKGZ-4口服液灌装轧盖机
4 heads oral liquid filling capping machine

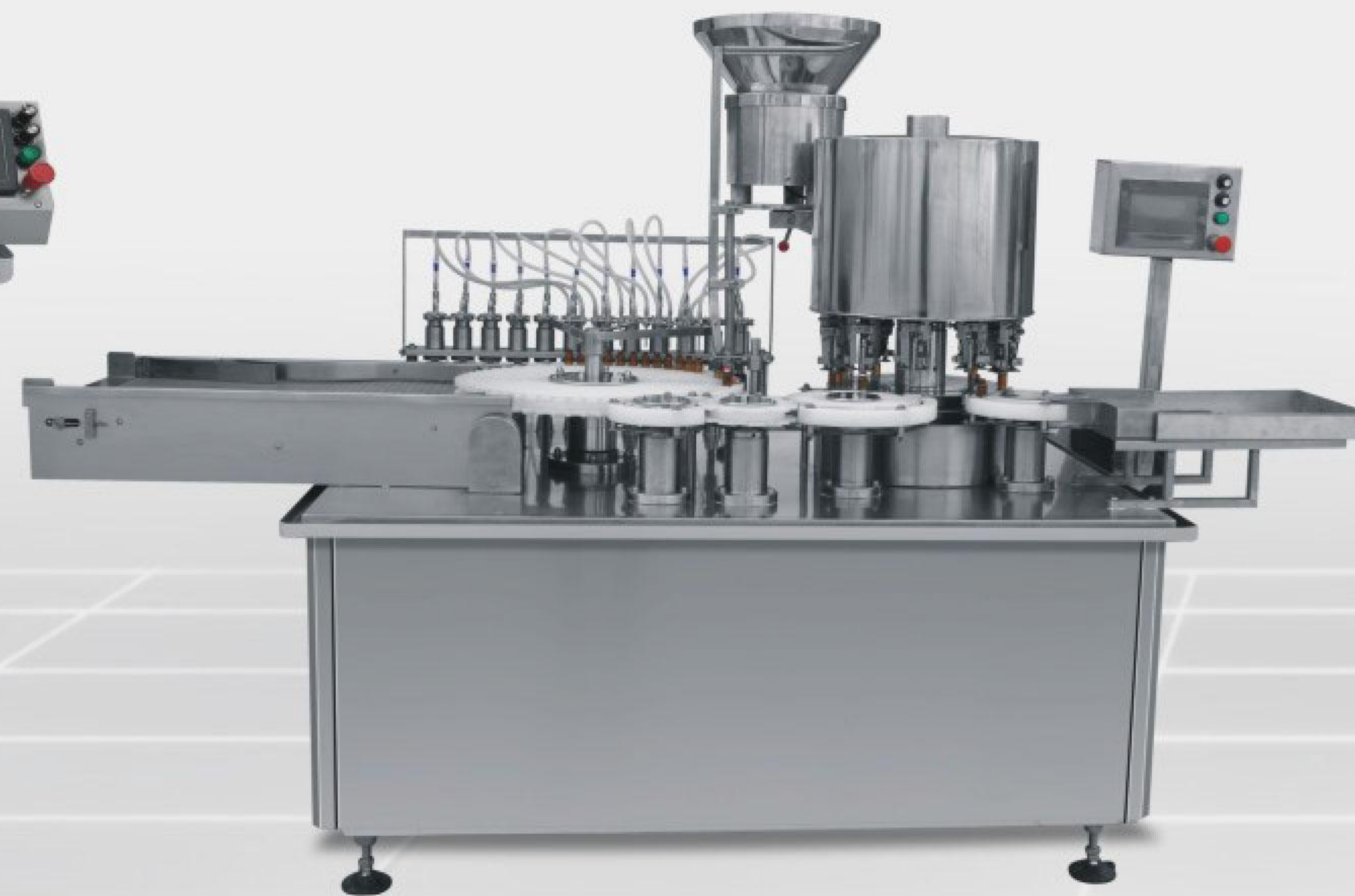

SGKGZ-12口服液灌装轧盖机
4 heads oral liquid filling capping machine



SGKGZ-16口服液灌装轧盖机
4 heads oral liquid filling capping machine

设备简介

- ◎口服液灌装轧盖机为大格公司传统设备。主要运用于5-25ml管制瓶灌装、加盖、轧盖;根据生产量的要求,现公司产品有2针、4针、12针、16针灌装轧盖设备。
- ◎口服液灌装轧盖机系列设备性能稳定,操作简单可靠,根据用户工艺要求配置可满足不同规格、不同产能的生产需要。

Equipment Brief introduction

- ◎Oral filling capping(roll) machine is GRAND company's traditional equipment. Mainly used for 5-25ml tube bottle filling, add cap, capping(); According to production speed, our company have 2 needle, 4 needle, 12 needle, 16 needle filling capping(roll) equipment.
- ◎Oral filling capping(roll) machine performance stable, operation is very simple, According to customer technological requirements configuration can satisfy different specifications and production speed.

技术参数 Technical Parameters

产品型号 Product No	SGKGZ-4	SGKGZ-12	SGKGZ-16
适用规格 Applicable specification	5-25ml	5-25ml	5-25ml
生产能力 Production speed	60-80瓶/分 b/m	150-200瓶/分 b/m	300-400瓶分 b/m
装量误差 Filling error	± 1~2%	± 1~2%	± 1~2%
破损率 Breakage rate	≤5%	≤5%	≤5%
电源 Power supply	220V/380V,1.5KW	220V/380V,3KW	220V/380V,5KW
重量 Weight	500KG	1500KG	2300kg
外形尺寸 Dimensions	1500 × 1000 × 1650mm	3500 × 1350 × 1750mm	3800 × 1650 × 1750mm



SGGZ-4灌装轧盖机
2 heads filling capping machine



SGGZ-8灌装轧盖机
2 heads filling capping machine



SGGZ-12灌装轧盖机
2 heads filling capping machine

设备简介

- ◎本系列口服液灌装轧盖机主要适用于20/30/50/60/100ml系列玻璃口服液瓶金属螺纹盖的灌装、加盖、轧螺纹盖；
- ◎灌装系统和轧盖系统在本系列机型上体现的淋漓尽致,装量精度高,无滴漏；
- ◎轧盖结构为我公司专利结构,轧盖螺纹光整、底刀平滑。有效保证了包装的品质!

Equipment Brief introduction

- ◎This series oral filling capping(roll) machine mainly used for 20/30/50/60/100ml glass bottle, metal thread cap's filling, add cap, capping(roll);
- ◎This series machine Filling system and capping(roll) system is embodied incisively and vividly, filling precision high, no dripping;
- ◎Capping(roll) structure is our company patent structure, capping(roll) smooth Effectively ensure the quality of the packaging.

技术参数 Technical Parameters

产品型号 Product No	SGGZ-4灌装轧盖机	SGGZ-8灌装轧盖机	SGGZ-12灌装轧盖机
适用规格 Applicable specification	20-100ml	20-100ml	20-100ml
生产能力 Production speed	40-60瓶/分 b/m	80-120瓶/分 b/m	200-250瓶/分 b/m
装量误差 Filling error	± 1~2%	± 1~2%	± 1~2%
电源 Power supply	220V,2KW	220V,2.5KW	220V,5KW
重量 Weight	1000KG	1600KG	3000KG
外形尺寸 Dimensions	2440 × 1350 × 1750mm	3000 × 1650 × 1750mm	4500 × 2000 × 1750mm

微量粉剂分装机

Powder Filling Machine Series

粉剂分装机适用于制药、生物制品及化学药剂。根据包装方式的不同可选用不同的设备结构。我公司采用伺服驱动高精度螺杆进行物料分装,装量可调整;根据包装方式可进行加盖旋盖、加盖轧盖、加塞加盖旋(轧)盖。产品设计合理,设备性能稳定可靠。

Powder filling machine is used for pharmaceuticals, biological products and chemicals. According to different packing method and choose different equipment structure. Our company use servo drive and high precision screw for material filling, filling amount adjustable; According to packing method choose add cap and capping, stoppering capping(roll). Machine design is reasonable, equipment performance is stable and reliable.



技术参数 Technical Parameters

产品型号 Product No	SGFJ微量粉剂分装加塞机
适用规格 Applicable specification	0.03-10g
生产能力 Production speed	35-400瓶/分 b/m
加塞盖合格率 Stoppering and add cap pass rate	>99%
装量误差 Filling error	± 3%
电容量 Power supply	220/380.3.5kW
净化压缩空气气压及耗气量 Purify compressed air pressure and air consumption	0.3-0.5mpa, 1-3m³/h
重量 Weight	800-2000KG
外形尺寸 Dimensions	4500 × 1650 × 1750mm

冻干液灌装半加塞机

Lyophilized Liquid Filling
Half Stoppering Machine

本机适用于制药行业对西林瓶进行自动溶液高精度灌装,同时进行自动加塞或半加塞采用PLC程序控制,融合先进智能电控技术、简洁直观的人机界面,实现了完美的机电一体化设计;具有无瓶不灌装,无瓶不加塞。外表采用优质304不锈钢材质,符合GMP规范要求。

This machine is suitable for automatic solution and high precision filling of Xilin bottle in pharmaceutical industry, Automatic stoppering or half stoppering at the same time. Using PLC program control, Integration of advanced intelligent electronic control technology, Concise and intuitive human-machine interface, Perfect mechatronics design is realized; It has no bottle, no filling, no bottle, no stoppering, the appearance is made of high quality SS 304, which meets the requirements of GMP specification.

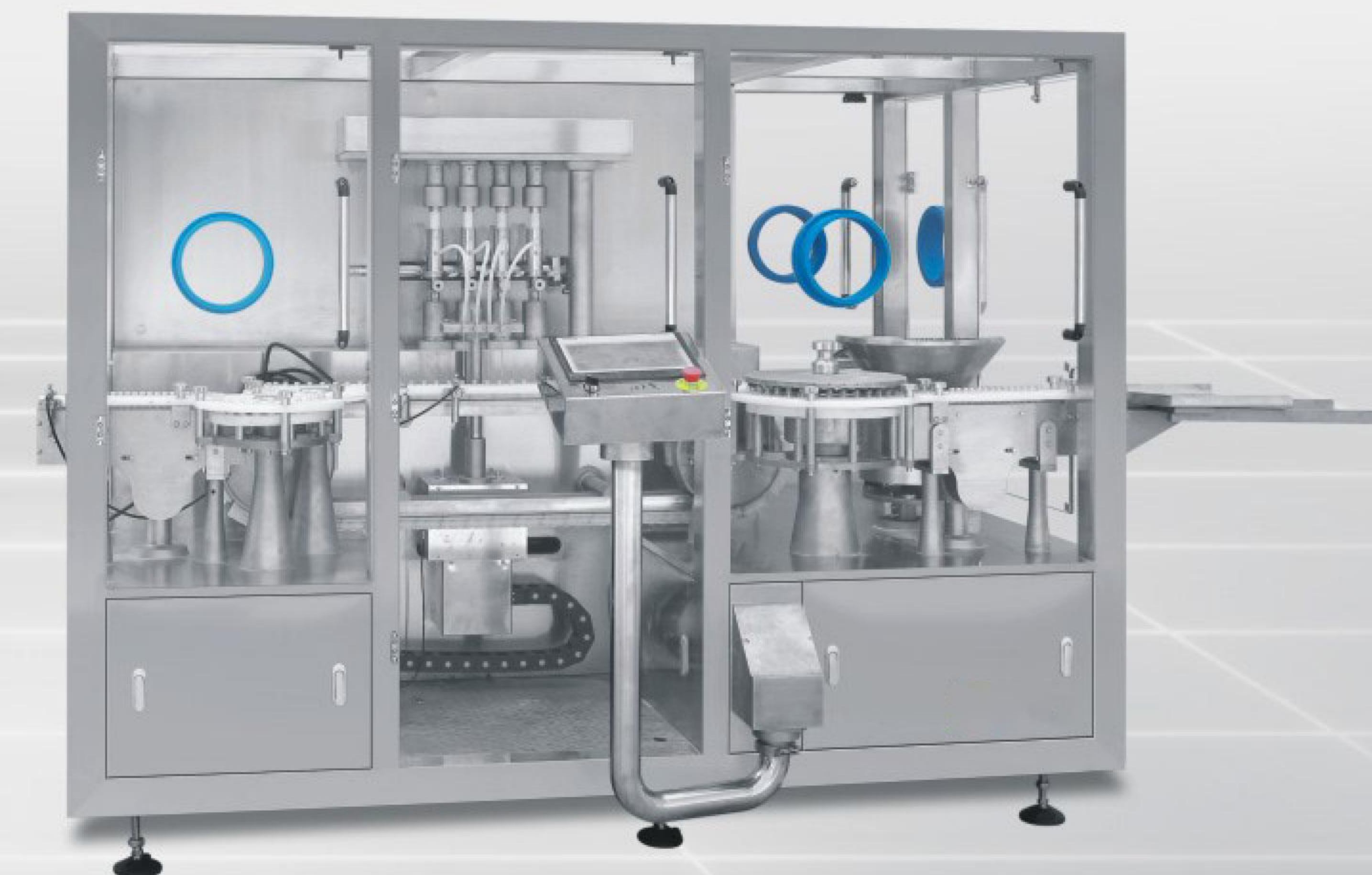

技术参数 Technical Parameters

产品型号 Product No	SGFJ微量粉剂分装加塞机
适用规格 Applicable specification	冻干液灌装半加塞机 0.1-10ml西林瓶(需订货时确定具体规格) 0.1-10ml penicillin bottle(confirm the specifications when ordering)
生产能力 Production speed	30-400瓶/分(按客户需求定制) 30-400 b/m(customized according to customer requirements)
加塞盖合格率 Stoppering and add cap pass rate	>99.9%
电容量 Power supply	3kw
重量 Weight	800-3000KG(视具体产量而定) 800-3000KG(Depending on production capacity)
外形尺寸 Dimensions	3000 × 2400 × 2400mm(视具体产量而定) 3000x2400x2400mm(Depending on production capacity)

玻璃瓶灌装机系列

Glass Bottle Filling Machine Series

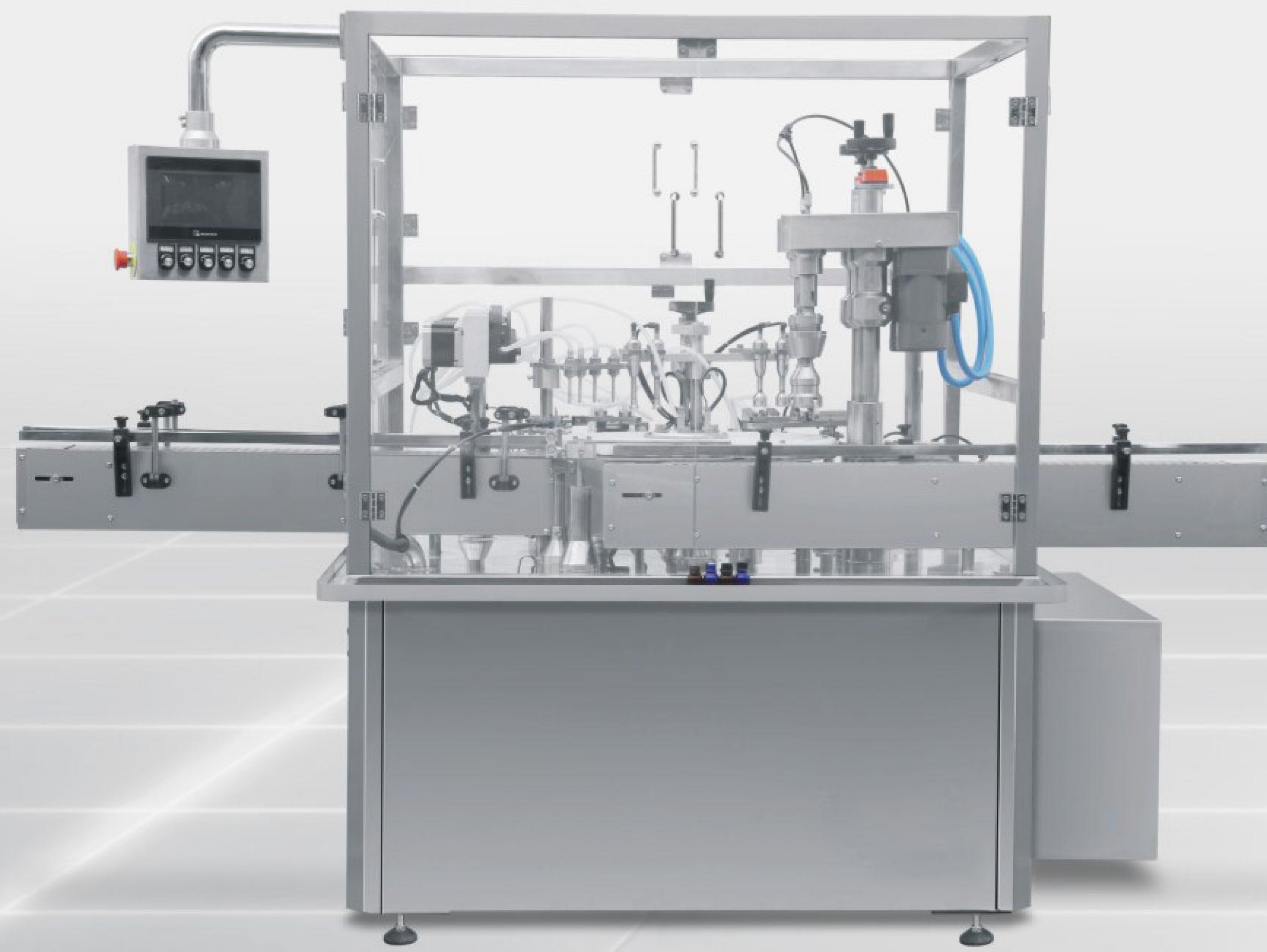

设备简介

本系列产品主要用于玻璃瓶的灌装、加塞、旋(轧)盖等生产动作,可按照客户的要求。满足不同物料、不同封口包装形式的灌装自动化生产,设备完全按照药机标准制造,广泛运用于制药、保健、食品、日化等行业,可与我公司的自动洗瓶机、隧道烘箱和贴标机等组成自动化生产线,减少人工,提高生产效率。

Equipment Brief introduction

This series of products mainly used for glass bottle filling, stoppering, capping(sealing) etc.Can be customized according to the customer's request.Meet different filling materiel、packing form' s automatic production,equipment fully conforms to the manufacture of pharmaceutical machinery standard,Widely used in pharmaceutical、health、food、daily chemicals and other industries, Can constitute production line with our company automatic bottle washing machine、tunnel oven and labeling machine etc,reduce labor and improve production efficiency.

技术参数 Technical Parameters

产品型号 Product No	SGBGZ型灌装轧盖机	SGBSZ型灌装加塞轧盖机	SGBX型灌装旋盖机	SGBSX型灌装加塞旋盖机
适用规格 Applicable specification	1-1000ml (订货时确定具体规格) 1-1000ml (when order machine confirm specific specifications)			
生产能力 Output	40-50瓶/分 40-50 B/M	80-100瓶/分 80-100 B/M	200-300瓶/分 200-300 B/M	
电源规格 Power	220V/380V/50Hz 2.5-6.0KW (根据速度选型而定) 220V/380V/50Hz 2.5-6.0KW (According to different output machine)			
重量 Weight	1000-3000KG (根据速度选型而定) 1000-3000KG (According to different output machine)			

塑料瓶灌装机系列

Plastic Bottle Filling Machine Series

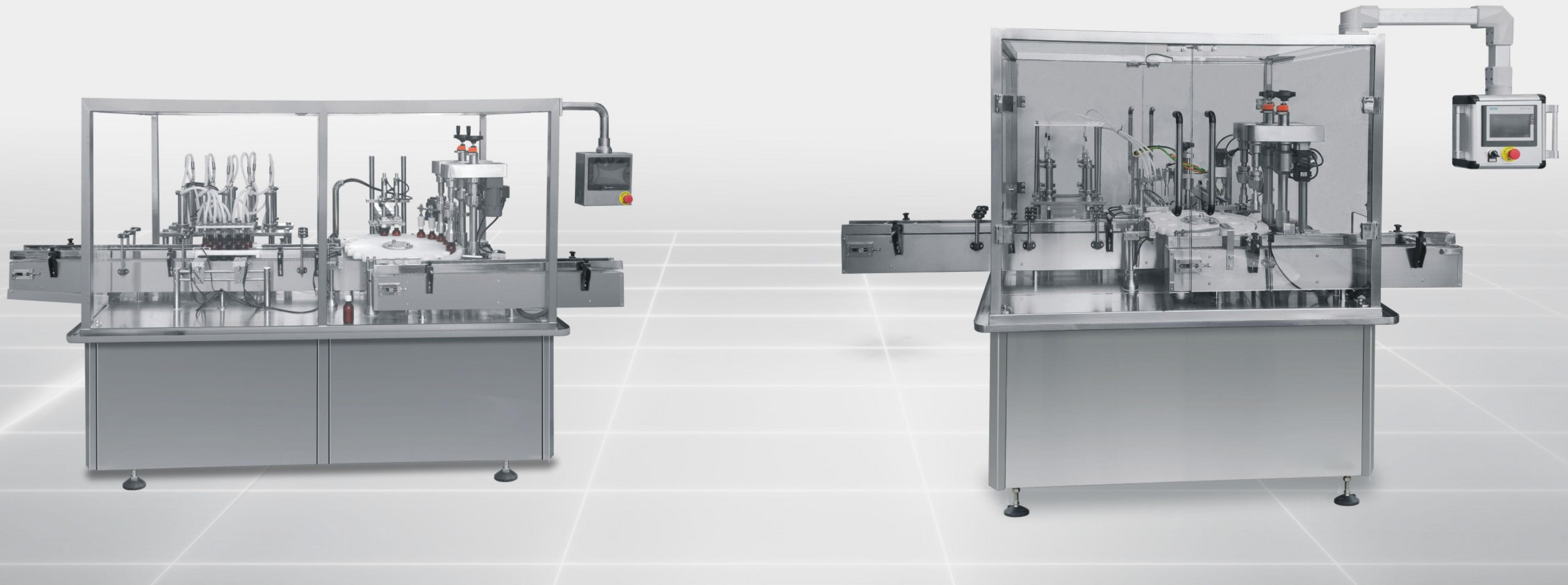

设备简介

本系列产品主要用于塑料瓶的灌装、加塞、旋（轧）盖等生产动作，可按照客户的要求。满足不同物料、不同封口包装形式的灌装自动化生产，设备完全按照药机标准制造，广泛运用于制药、保健、食品、日化等行业，可与我公司的自动理瓶机、气洗机和贴标机等组成自动化生产线，减少人工，提高生产效率。

Equipment Brief introduction

This series of products mainly used for plastic bottle filling, stoppering, capping(sealing)etc.Can be customized according to the customer's request.Meet different filling materiel、packing form' s automatic production,equipment fully conforms to the manufacture of pharmaceutical machinery standard,Widely used in pharmaceutical、health、food、daily chemicals and other industries, Can constitute production line with our company automatic bottle unscrambler machine 、air washing machine and labeling machine etc,reduce labor and improve production efficiency.

技术参数 Technical Parameters

产品型号 Product No	SGSGZ型灌装轧盖机	SGSSZ型灌装加塞轧盖机	SGSGX型灌装旋盖机	SGSSX型灌装加塞旋盖机
适用规格 Applicable specification	1-1000ml (订货时确定具体规格) 1-1000ml (when order machine confirm specific specifications)			
生产能力 Output	40-50瓶/分 40-50 B/M	80-100瓶/分 80-100 B/M	200-300瓶/分 200-300 B/M	
电源规格 Power	220V/380V/50Hz 2.5-6.0KW (根据速度选型而定) 220V/380V/50Hz 2.5-6.0KW (According to different output machine)			
重量 Weight	1000-3000KG (根据速度选型而定) 1000-3000KG (According to different output machine)			

其他灌装机系列

Other Filling Machine Series

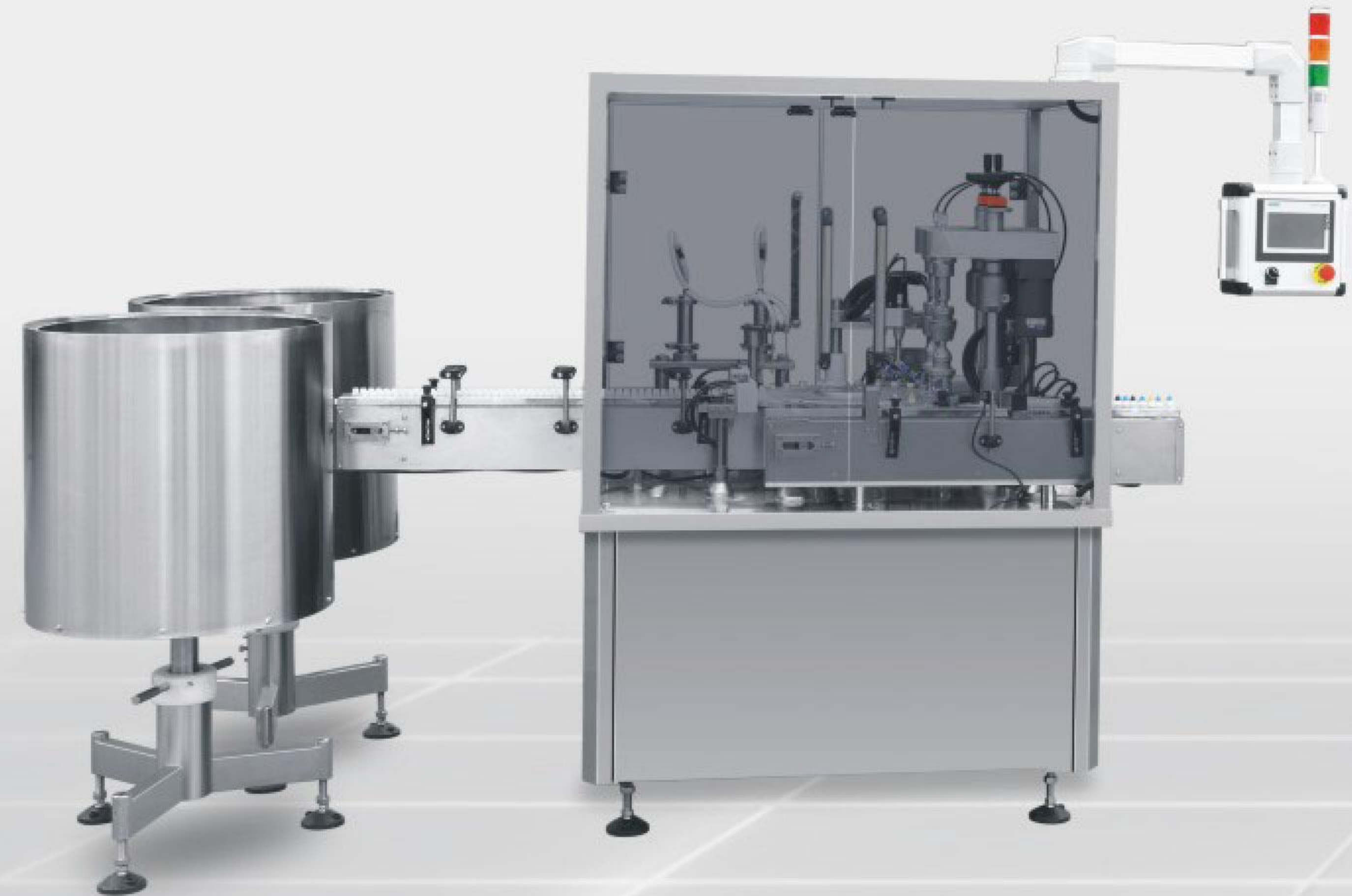

SGSJ型微量试剂灌装机
SGSJ-Micro reagent filling machine

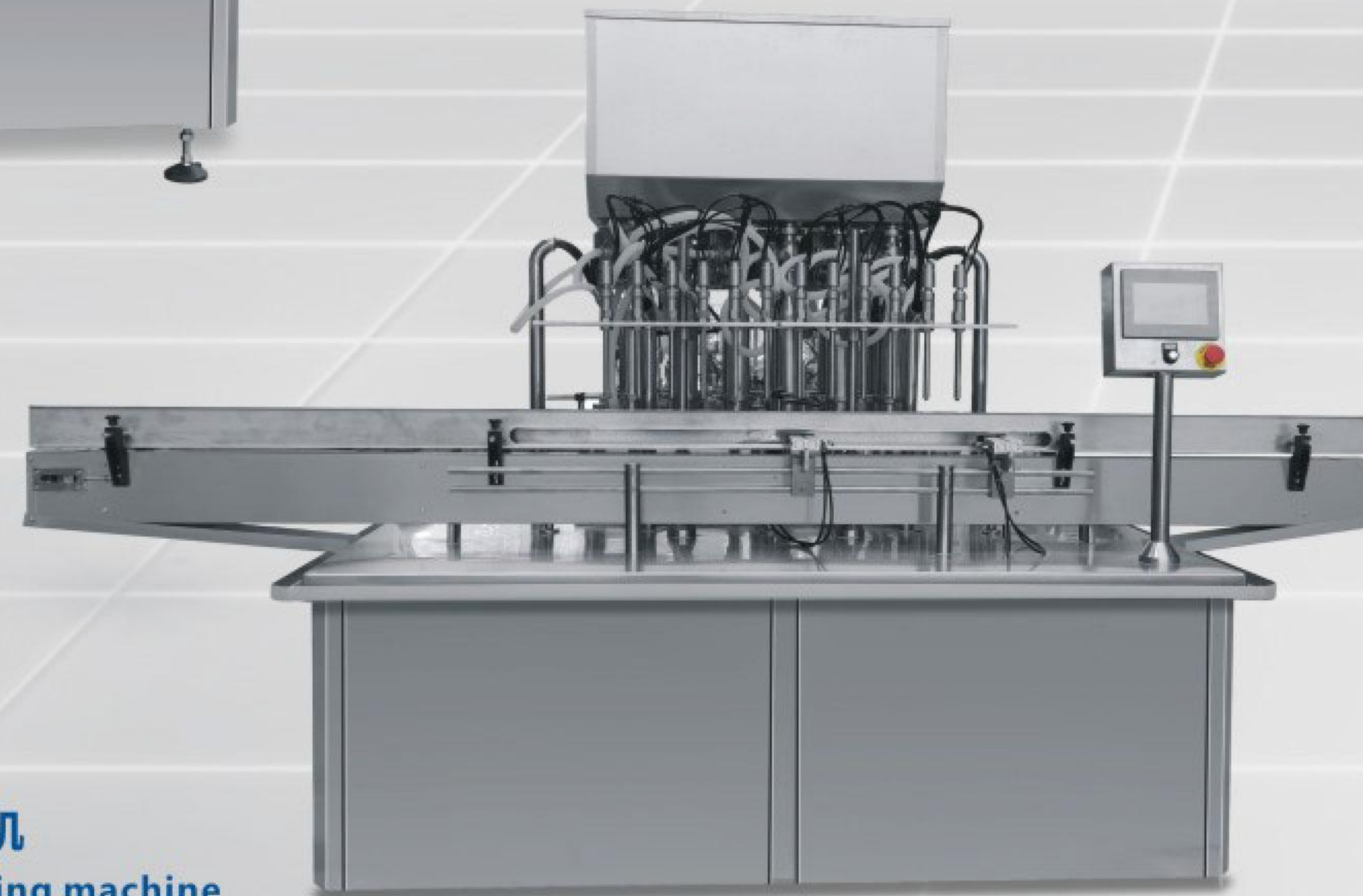

SGGG型膏体灌装机
SGGG-Ointment filling machine



SGGY型灌装压盖机
SGGY-Filling press cap machine



SGFW型膏体灌装封尾机
SGFW-Ointment filling sealing machine

设备简介

本系列产品主要是按照客户需求，进行非标设计，针对非标准化的包材进行自动化生产，如诊断试剂、微量灌装、异形瓶、特殊物料等，都可以按照客户提供的原料进行设计，达到自动化生产的目的。

Equipment Brief introduction

This series of products mainly according to customer needs, non-standard design, for non-standard packing material automatic production, such as diagnostic reagent, micro-filling, special-shaped bottle, special material etc, all can design according to the raw material provided by the customer, achieve the purpose of automated production.

技术参数 Technical Parameters

产品型号 Product No	SGSJ型微量试剂灌装机	SGGG型膏体灌装机	SGGY型灌装压盖机	SGFW型膏体灌装封尾机
适用规格 Applicable specification	50-2000um	1-1000克 g	0.5-1000ml	1-1000克 g
生产能力 Output	40-100瓶/分 B/M	40-120瓶/分 B/M	40-50瓶/分 B/M	40-50瓶/分 B/M
电源规格 Power	220V/380V/50Hz 2.5-6.0KW (根据速度选型而定) (According to different output machine)			
重量 Weight	500-2000KG (根据速度选型而定) (According to different output machine)			

搓盖机,西林瓶轧盖机

Twist Capping Machine, Vial Bottle
Multi-head Capping Machine



SGCG搓盖机
Twist capping machine



SGZG西林瓶轧盖机
Vial bottle capping machine

设备简介

- ◎ 旋(轧)盖机为圣灌传统设备。
- ◎ 适用于各类塑料盖、金属(复合)盖、螺旋盖、防盗盖、压入盖等。
- ◎ 根据盖型及瓶型,生产能力需求进行设备选型。旋盖采用磁力旋盖结构,轧盖采用三刀轧盖或四刀轧盖等。
- ◎ 本系列设备结构稳定可靠。

Equipment Brief introduction

- ◎ Capping(roll) machine is Shengguan traditional equipment.
- ◎ Suitable for all kinds plastic cap, metal (composite) cover, screw thread cap, anti theft cap, press cap etc.
- ◎ According to cap type and bottle type, production speed choose equipment Capping use magnetic force capping structure, rolling cap use three knife capping or four knife capping.
- ◎ This series equipment structure is stable and reliable.

技术参数 Technical Parameters

产品型号 Product No	SGCG搓盖机	SGZG西林瓶轧盖机
适用规格 Applicable specification	30-500ml	2-20ml
生产能力 Production speed	40-300瓶/分 b/m	40-400瓶/分 b/m
成品合格率 Stoppering and add cap pass rate	99%	>99%
电容量 Power supply	220/380v,2.5kW	220/380V,2.5KW
净化压缩空气气压及耗气量 Purify compressed air pressure and air consumption	0.3-0.5pa1-3m3/h	/
重量 Weight	550KG	500KG
外形尺寸 Dimensions	2440 × 1650 × 1750mm	2000 × 1350 × 1750mm

立式贴标机系列

Vertical labeling machine series

本系列产品主要用于可站立圆形瓶的不干胶贴标，输送带自动送瓶，设备自动分瓶，光电感应出标，可按客户产量需求选择不同机型。

This series product mainly use for round bottle which can stand in conveyor belt adhesive labeling, conveyor belt automatic moving bottle, automatic separate bottle, photoelectric induction out label, according to customer need output choose different machine.

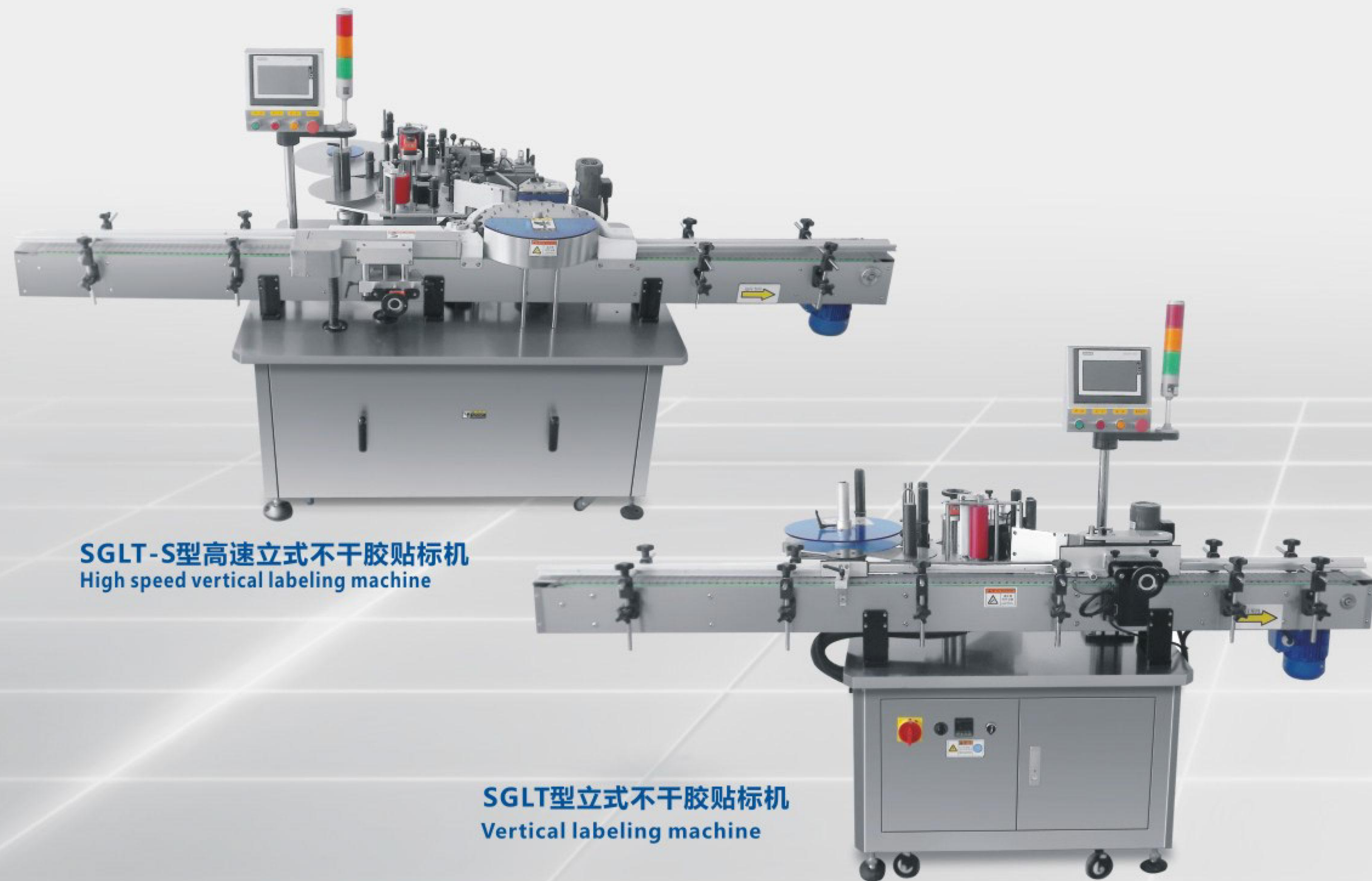

SGLT-S型高速立式不干胶贴标机
High speed vertical labeling machine

SGLT型立式不干胶贴标机
Vertical labeling machine

技术参数 Technical Parameters

产品型号 Product No	SGLT型立式不干胶贴标机	SGLT-S型高速立式不干胶贴标机
适用规格Applicable specification	1-1000ml	1-1000ml
生产能力Output	40-200瓶/分b/m	200-400瓶/分b/m
电源Power supply	380/220V, 2.5KW	380/220V, 3.5KW
重量Weight	250kg	600kg
尺寸Dimension	2000*1200*1450	3500*2000*1800mm

卧式贴标机系列

Horizontal labeling machine series

本系列产品主要用于直径较细的瓶子进行贴标生产动作，考虑到瓶身细长的瓶子站立困难，特进行躺卧式设计，拨轮自动分瓶，输送带自动送瓶，光电感应出标，可按客户产量需求选择不同机型。

This series products mainly use for diameter small bottle labeling. Considering the thin bottle difficulty standing in conveyor belt, so design horizontal labeling machine, dialing wheel automatic separate bottle, conveyor belt automatic moving bottle, photoelectric induction out label, It can according to customer need choose different machine.

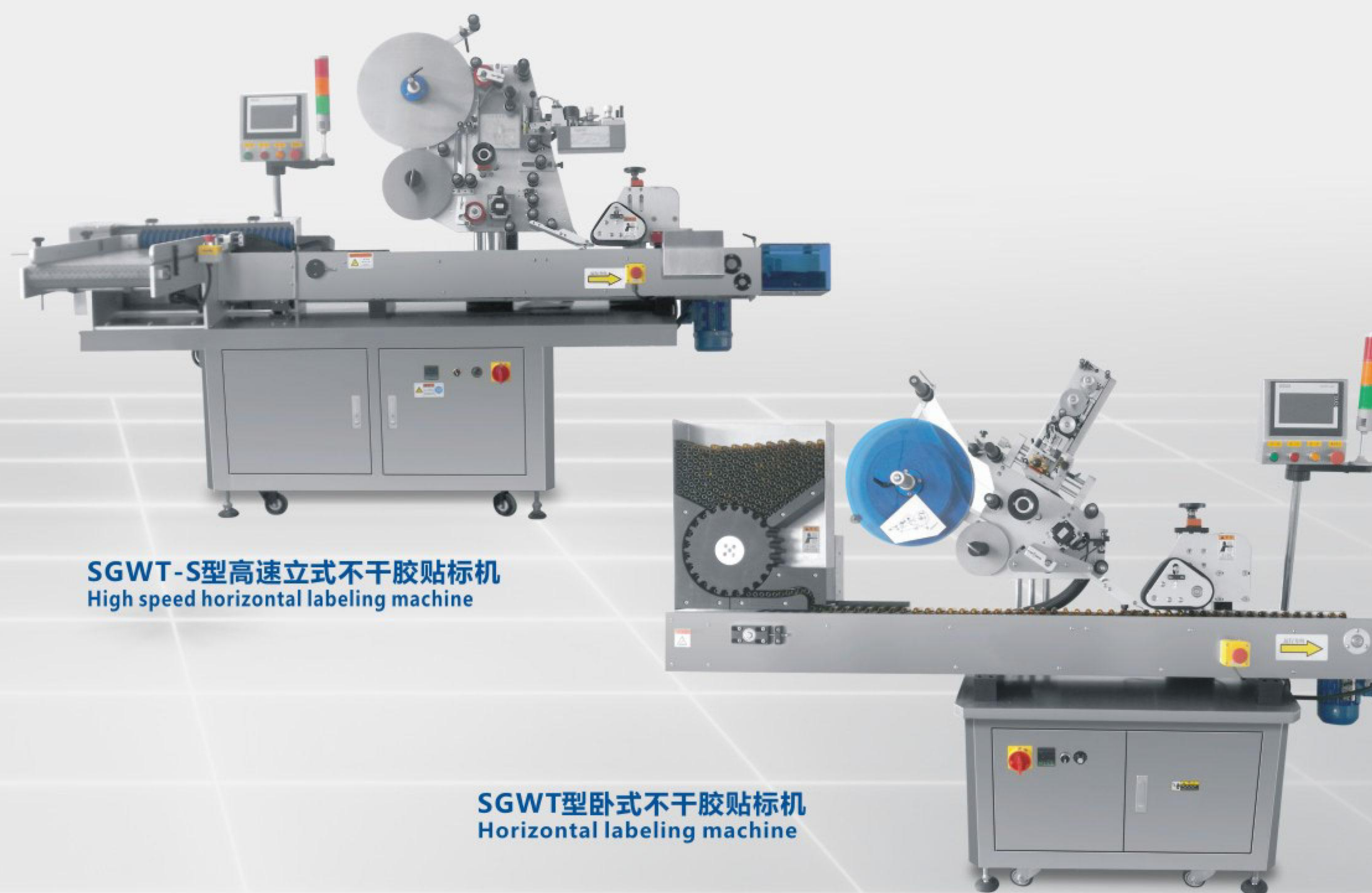

SGWT-S型高速立式不干胶贴标机
High speed horizontal labeling machine

SGWT型卧式不干胶贴标机
Horizontal labeling machine

技术参数 Technical Parameters

产品型号 Product No	SGWT型卧式不干胶贴标机	SGWT-S型高速立式不干胶贴标机
适用规格Applicable specification	1-100ml	1-100ml
生产能力Output	40-200瓶/分b/m	200-400瓶/分b/m
电源Power supply	220V, 2.5KW	220V, 3.5KW
重量Weight	250kg	600kg
尺寸Dimension	2000*800*1450	3000*1500*1800mm

其他贴标机系列

Other labeling machine series

本系列产品主要用于方扁瓶的双面贴标和顶面贴标，输送带自动送瓶，光电感应出标，可按客户生产需求选择不同机型。

This series product mainly use for flat bottle double side labeling and top side labeling, conveyor belt automatic moving bottle, photoelectric induction out label, It can according to customer need choose different machine.

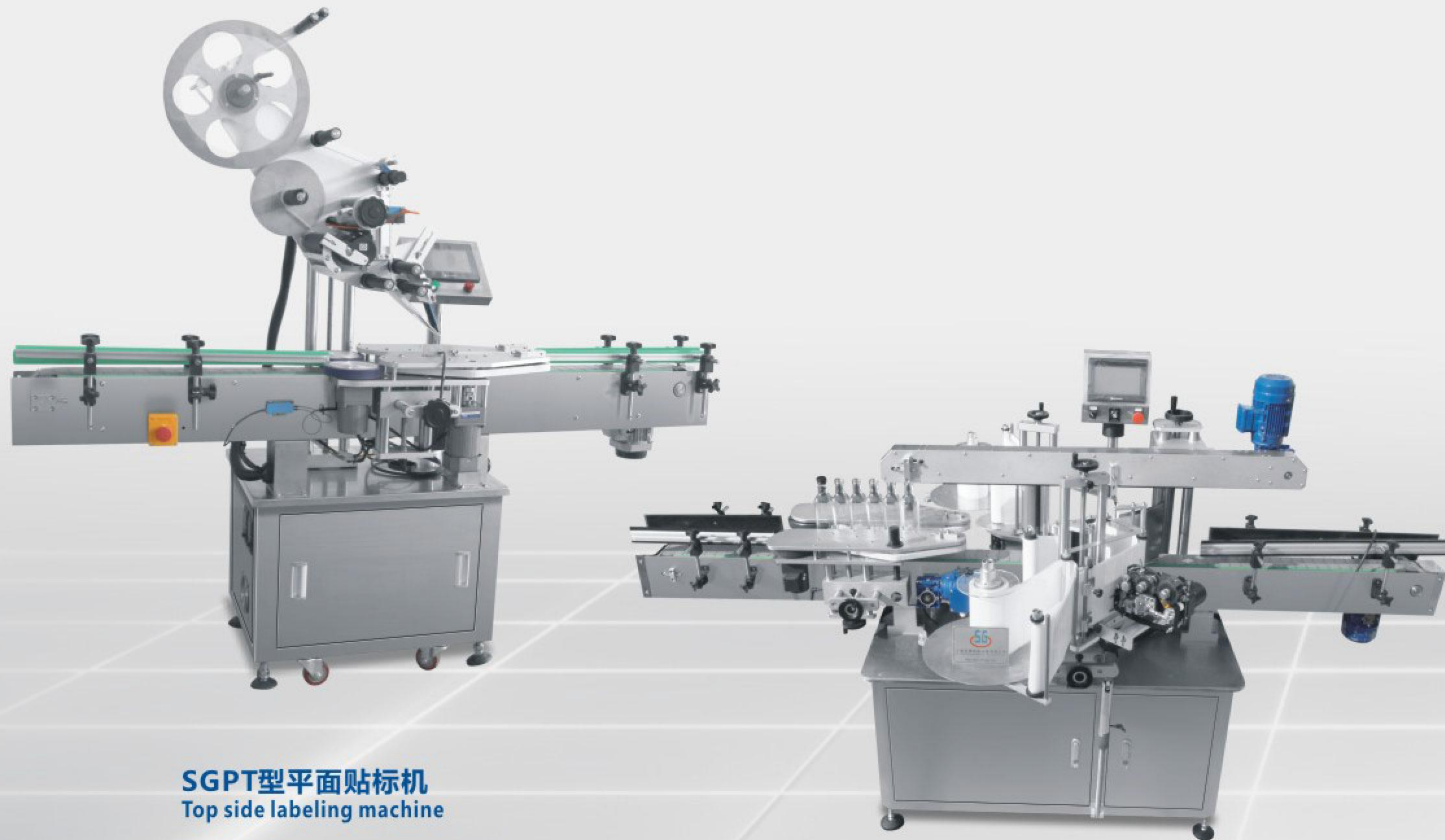

SGPT型平面贴标机
Top side labeling machine

SGST型双面贴标机
Top side labeling machine

技术参数 Technical Parameters

产品型号 Product No	SGPT型平面贴标机	SGST型双面贴标机
适用规格Applicable specification	1-1000ml	1-1000ml
生产能力Output	40-100瓶/分 b/m	40-100瓶/分 b/m
电源Power supply	220V, 2.5KW	220V, 3.5KW
重量Weight	250kg	600kg
尺寸Dimension	2000*800*1450	3000*1500*1800mm

包装机系列

Packing machine series



立式包装机 Vertical packing machine

本机主要用于制药、食品行业的物料包装，如粉剂、膏体、液体、颗粒剂等产品，可按照客户需求定制成型，可选两边背封、三边封、四边封等包装形式。

This machine mainly used in the packaging of materials in the pharmaceutical and food industry, such as powder, ointment, liquid, granules etc products, It can according to customer requirement custom-made, It can choose two, three, four side packing form.



SGBZ型立式包装机
Vertical packing machine

枕式包装机 Pillow packaging machine

本机主要用于制药、食品行业的物料包装，如凝胶管、面包、方便面、蛋黄派、雪糕、饼干、医药用品等有规则物体的包装。

This machine mainly used in the packaging of materials in the pharmaceutical and food industry, Such as gel tube, bread, instant noodles, cake, biscuits, medical supplies etc packing.



SGZB型枕式包装机
Pillow packaging machine

技术参数 Technical Parameters

产品型号 Product No	SGZB型枕式包装机	SGBZ型立式包装机
生产能力Output	40-100包/分 bag/min	40-80包/分 bag/min
电源Power supply	220V, 2.5 KW	220V, 2.5 KW
设备重量Weight	250kg	250kg
尺寸Dimension	4500*800*1450mm	800*800*1850mm

终端灭菌系列

Terminal sterilization series

该灭菌器广泛运用于制药企业，医疗单位对药品、保健品、口服液的灭菌处理，具有高温灭菌、快速冷却等先进功能，结构合理、功能齐全是制剂行业和口服液等灭菌的首选灭菌设备，随时可以对柜内各温控点检测。本机设计合理、运行稳定可靠，完全符合GMP要求。

The sterilizer is widely used in pharmaceutical enterprises, and the sterilization treatment of medicines, health products and oral liquids by medical units, with high temperature sterilization, rapid cooling and other advanced functions, reasonable structure and complete function are the first choice sterilization equipment for the preparation industry and oral liquid, and can be detected at any temperature control points in the cabinet at any time. The machine is reasonable in design, stable and reliable in operation, and fully meets the requirements of GMP.



技术参数 Technical Parameters

产品型号 Product No	SGZM型蒸汽式灭菌柜
适用规格Applicable specification	1-1000ml
生产能力Output	2000-20000瓶/时 (按客户实际产量定制) (Customizing according to the actual output of the customer)
电源Power supply	380V/50Hz 3.0KW
重量Weight	1000-3500KG
尺寸Dimension	(1000-1800) * (1400-3500) * (1800-2400) mm 视产量大小而定Depending on the output

喷淋式杀菌机

Terminal sterilization series

喷淋杀菌冷却隧道，是专门为乳品、果汁、饮料、啤酒、食品、药品等灌装或包装后的巴氏灭菌设备，是物料通过杀菌、冷却达到延长保质期目的的理想设备，特别是自动化生产线必备的二次灭菌设备。可根据用户对不同产品的加热、杀菌、保温、冷却的不同工艺要求，进行不同的流程设计，满足工艺要求，配置相应的高精度的自动控制系统。喷淋杀菌隧道比传统的水浴杀菌热分布更均匀，更渗透，更迅速，大大提高了生产效率。

The spray sterilization and cooling tunnel is an ideal equipment for pasteurization, which is specially designed for milk, juice, drink, beer, food, medicine and so on. It is the ideal equipment for the material to prolong the shelf life through sterilization and cooling, especially the two equipment which is necessary for the automation production line. According to the different process requirements of heating, sterilization, heat preservation and cooling of different products, different process design can be carried out to meet the requirements of the process, and the corresponding high precision automatic control system can be configured. The spray sterilization tunnel is more uniform, more penetrating and faster than the traditional water bath sterilization heat, and greatly improves the production efficiency.



技术参数 Technical Parameters

产品型号 Product No	SGPL型喷淋式杀菌机
适用规格Applicable specification	10-1000ml
生产能力Output	2000-20000瓶/时 (按客户实际产量定制) (Customizing according to the actual output of the customer)
电源Power supply	380V/50Hz 3.5KW
重量Weight	1000-5000kg
尺寸Dimension	(8000-24000) * (1500*2500) * (1600*2200) mm 视产量大小而定Depending on the output